

  
**FERRARO®**

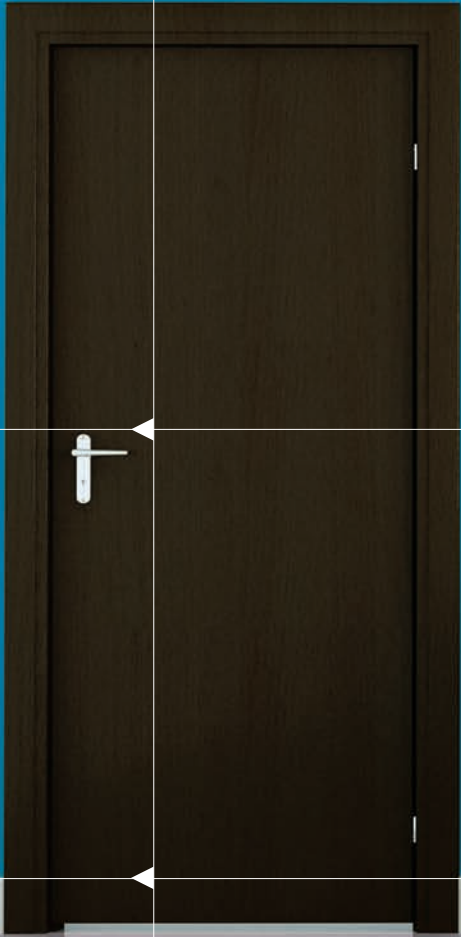

**OBELIX**  
CATALOGO  
RIVESTIMENTI

 **LIVING®**

# O B E L I X



AZIENDA CERTIFICATA UNI EN ISO 9001:2008 - SISTEMA DI GESTIONE QUALITÀ CERTIFICATO





## INDICE

- 4 FUTURA RIVESTIMENTI LISCI
- 6 EDISON RIVESTIMENTI INTARSIATI
- 10 ERIS RIVESTIMENTI SPAZZOLATI
- 12 OMNIA RIVESTIMENTI PANTOGRAFATI
- 30 VICTORIA RIVESTIMENTI MASSELLO
- 44 WOOD RIVESTIMENTI LEGNO MASSELLO ANTICATO
- 48 ARCADIA STYLE RIVESTIMENTI ALLUMINIO
- 54 ARCADIA CLASSIC RIVESTIMENTI ALLUMINIO
- 62 ARCADIA ECO RIVESTIMENTI ALLUMINIO
- 66 ATENA RIVESTIMENTI PVC
- 72 GRATE IN ACCIAIO ZINCATO
- 76 INFORMAZIONI TECNICHE



FUTURA





# OBELIX FUTURA

RIVESTIMENTI LISCI

## STRUTTURA

- verniciato legno su supporto MDF controbilanciato;
- truciolare controbilanciato e impiallacciato in varie essenze;
- laminatino su supporto MDF controbilanciato;
- laccato opaco-liscio o lucido-liscio, su supporto MDF.

## VERNICIATURA







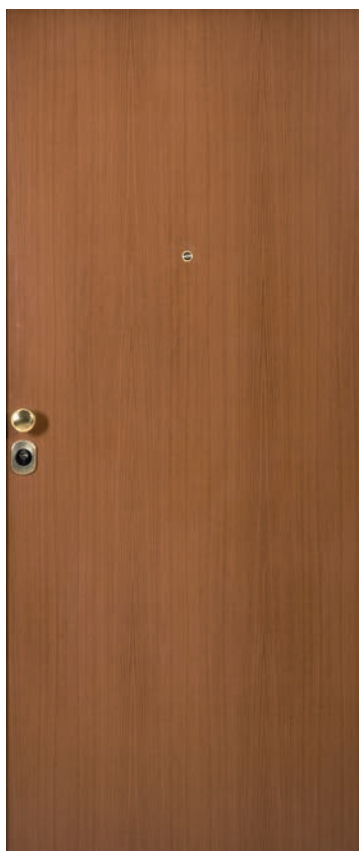
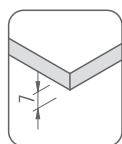



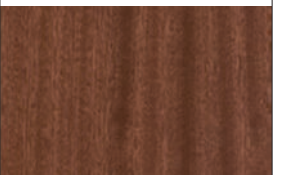

Essenza: tinteggiati e verniciati trasparente.  
Laccati: con vernice poliuretanaica.

## PANNELLO

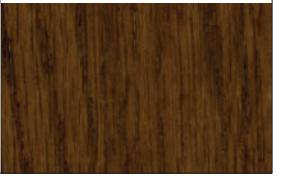
Spessore mm 7.

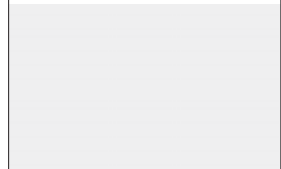

Essenza  
Tanganica  
Tinto noce medio 2

<p><b>1</b> Tanganica naturale leggermente tinto - verniciato legno - impiallacciato</p> 	<p><b>2</b> Tanganica tinto noce medio - verniciato legno - impiallacciato</p> 	<p><b>3</b> Mogano medio - verniciato legno - impiallacciato <b>4</b> Mogano lucido - impiallacciato</p> 	<p><b>5</b> Mansonia tinto noce medio - verniciato legno - impiallacciato</p> 	<p><b>6</b> Noce nazionale tinto noce medio - verniciato legno - impiallacciato</p> 
<p><b>7</b> Ciliegio naturale leggermente tinto - verniciato legno - impiallacciato</p> 	<p><b>8</b> Rovere naturale leggermente tinto - verniciato legno - impiallacciato</p> 	<p><b>9</b> Rovere tinto noce medio - verniciato legno - impiallacciato</p> 	<p><b>10</b> Rovere sbiancato - verniciato legno - impiallacciato <b>17</b> Rovere sbiancato - laminatino</p> 	<p><b>11</b> Rovere tinto wengè - verniciato legno - impiallacciato <b>18</b> Wengè a poro aperto - laminatino</p> 
<p><b>12</b> MDF laccato bianco opaco <b>12</b> Laminatino bianco opaco</p> 	<p><b>13/1013</b> MDF laccato RAL 1013 opaco</p> 	<p><b>RAL LACCATO</b> <b>13/...</b> OPACO LISCIO</p> 	<p><b>RAL LACCATO</b> <b>23/...</b> LUCIDO LISCIO</p> 	<p><b>N.B.</b> Per i laminatini le misure che si possono realizzare sono: 1 Anta misura max. cm 90x210 2 Ante, anta grande misura max. cm 90x210. I colori e le venature dei legni sono da ritenersi indicativi. Consultare la "Cartella rivestimenti".</p>



 **FERRARO**  
LIVING®

EDISON



**STRUTTURA**

- supporto MDF controbilanciato impiallacciato in varie essenze;
- filetti in tulipier nei colori marrone o nero e in rovere o acero nei colori chiari.

**VERNICIATURA**

tinteggiati e verniciati trasparente.

**PANNELLO**

Spessore mm 7.

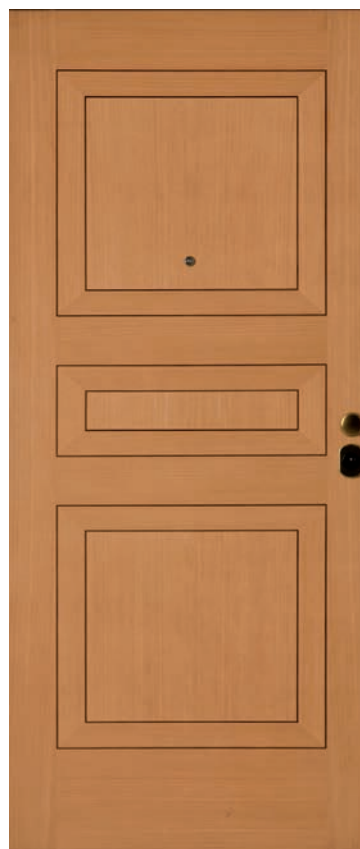
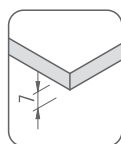

**MOD. 303**  
Essenza  
Tanganica naturale 1



**MOD. 301**  
Essenza Tanganica naturale 1



**MOD. 302**  
Essenza Tanganica naturale 1 e  
radica di noce

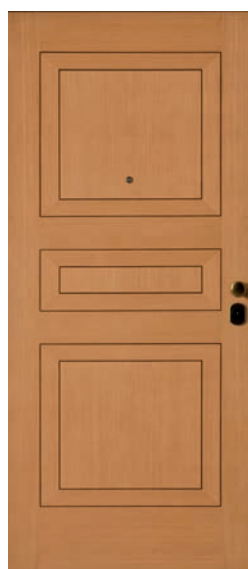

**MOD. 303**  
Essenza Tanganica naturale 1

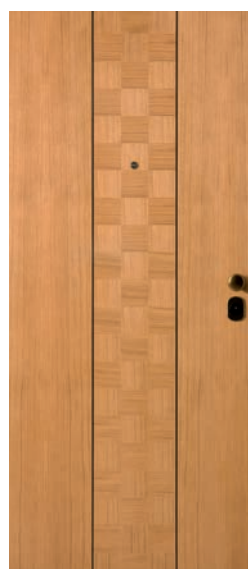

**MOD. 304**  
Essenza Rovere naturale 8



**MOD. 305**  
Essenza Tanganica naturale 1 con  
inserto radica di noce

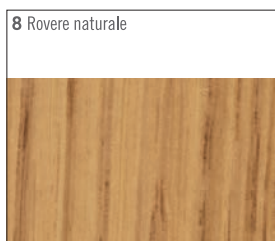
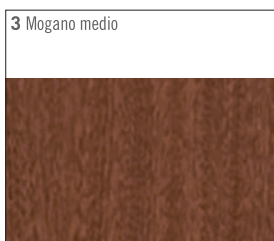



# OBELIX EDISON

RIVESTIMENTI INTARSIATI

8

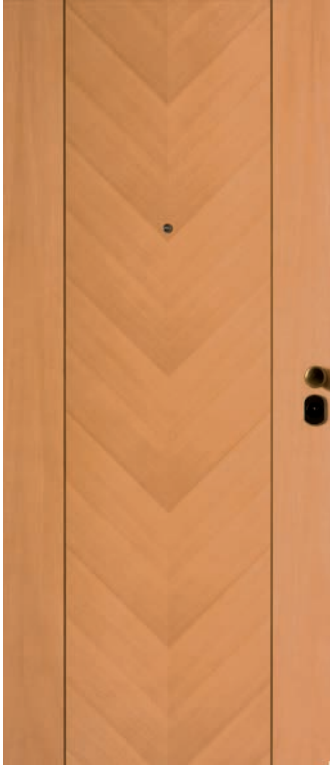

**MOD. 306**  
Essenza Tanganica naturale 1



**MOD. 307**  
Essenza Tanganica naturale 1



**MOD. 308**  
Essenza Tanganica naturale 1

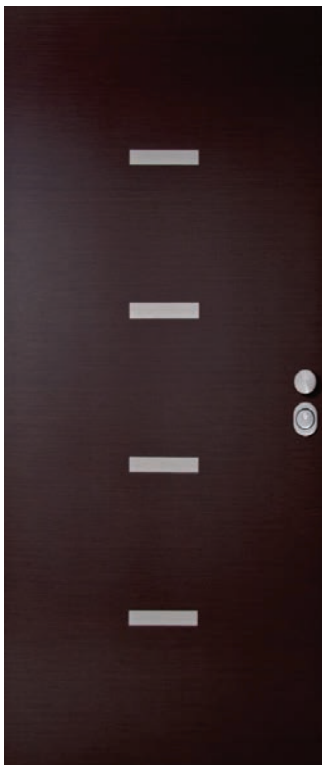

**MOD. 329**  
Essenza Rovere tinto wengè 11  
filetti cromo satinati

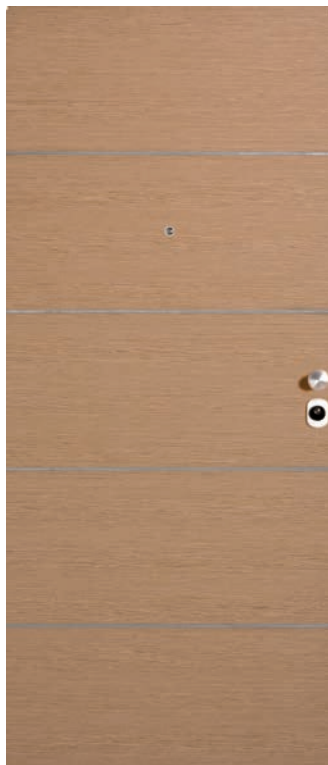

**MOD. 309**  
Essenza Rovere sbiancato 10  
filetti cromo satinati

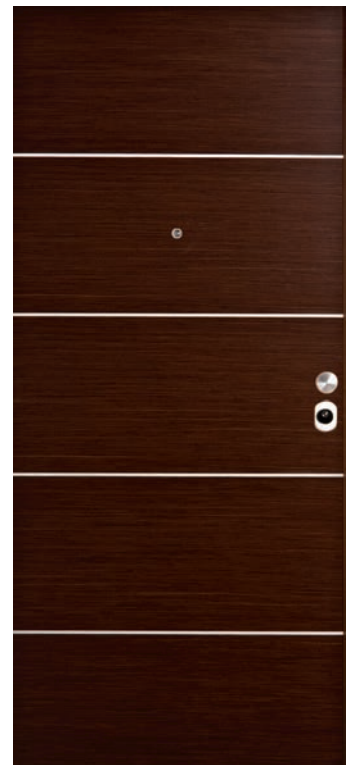

**MOD. 309**  
Essenza Rovere tinto wengè 11  
filetti cromo satinati





# OBELIX EDISON

DISEGNI RIVESTIMENTI INTARSIATI

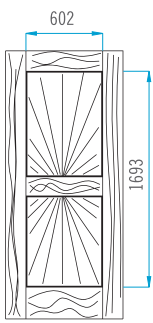

MOD. 301 (1-3-8)

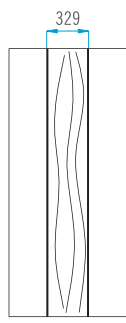

MOD. 302 (1-3-8)

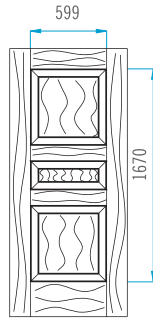

MOD. 303 (1-8)

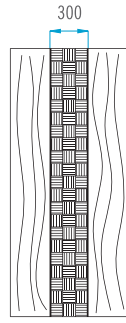

MOD. 304 (1-3-8)

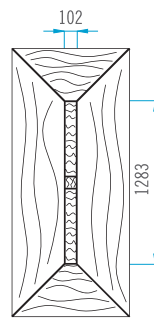

MOD. 305 (1-3-8)

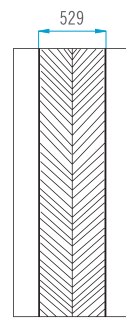

MOD. 306 (1-3-8)

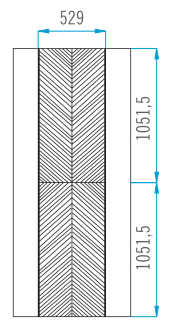

MOD. 307 (1-3-8)

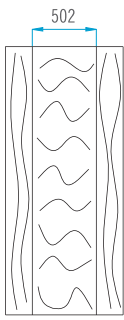

MOD. 308 (1-3-8)

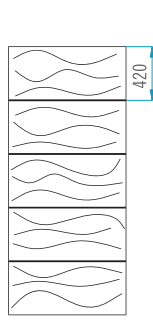

MOD. 309 (8-10-11)  
RAL laccato

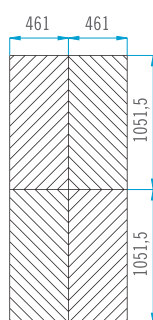

MOD. 311 (1-3-8)

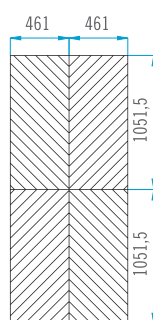

MOD. 312 (1-3-8)

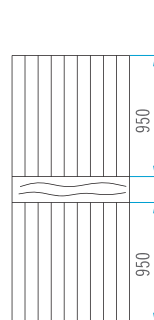

MOD. 313 (1-3-8)

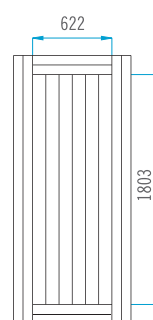

MOD. 314 (1-3-8)

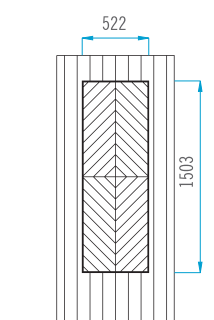

MOD. 315 (1-3-8)

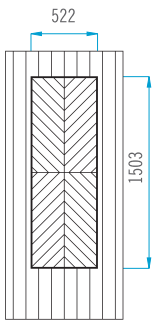

MOD. 316 (1-3-8)

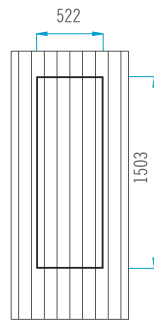

MOD. 317 (1-3-8)

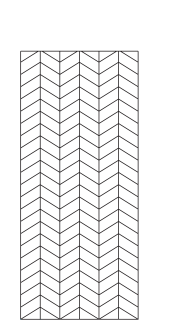

153 MOD. 318 (1-3-8)

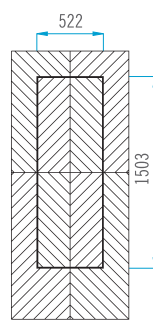

MOD. 319 (1-3-8)

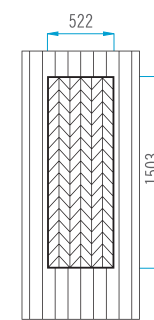

MOD. 320 (1-3-8)



MOD. 321 (1-3-8)

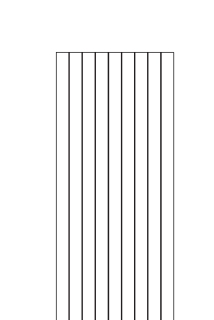

100 MOD. 322 (1-3-8)

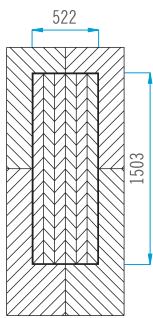

MOD. 323 (1-3-8)

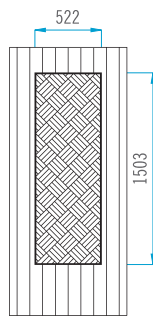

MOD. 324 (1-3-8)

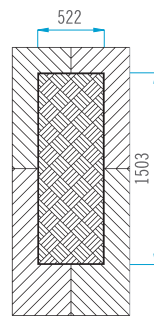

MOD. 325 (1-3-8)

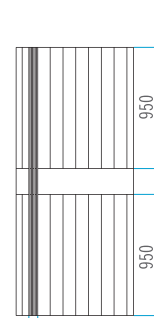

70 MOD. 326 (1-3-8)

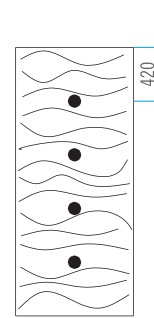

MOD. 327 (3-10-11)

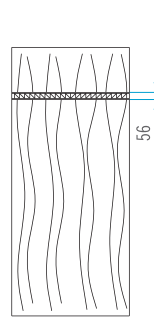

MOD. 328 (1-3)

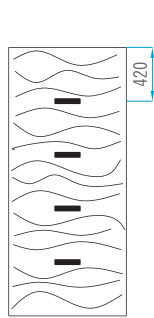

MOD. 329 (3-10-11)

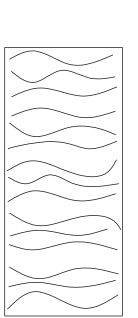

MOD. 330 (1-3)

N.B. Tra le parentesi sono indicate le essenze delle impiaccature.

Tutti i disegni sono per porte blindate di luce netta 90x210, cambiando le misure, i disegni avranno delle variazioni nelle proporzioni.



 **FERRARO**  
LIVING®

ERIS



# OBELIX ERIS

RIVESTIMENTI SPAZZOLATI

## STRUTTURA

supporto MDF controbilanciato impiallacciato in essenza yellow pine.

## VERNICIATURA

Essenza: verniciati con mordenzature scure.

## PANNELLO

Spessore mm 6.

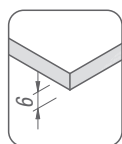

Essenza  
Yellow pine RAL 9006

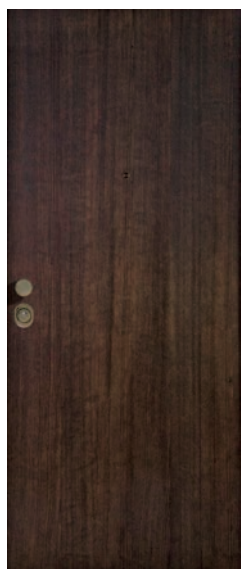

Essenza Yellow pine tinto wengè

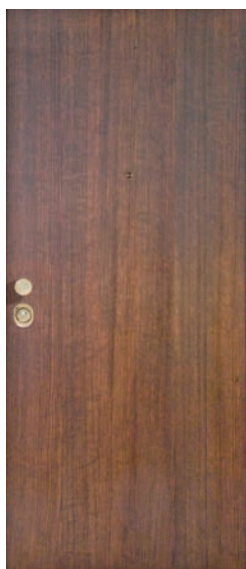

Essenza Yellow pine tinto noce medio



Essenza Yellow pine RAL 9006



Essenza Yellow pine RAL 9007



**N.B.**  
Misure massime realizzabili  
cm 119x249.  
I laccati possono essere sia  
opachi che lucidi.





 **FERRARO**  
LIVING®

OMNIA



**STRUTTURA**

- stratificato marino a fibre parallele in okumè naturale, o impiallacciato rovere o ciliegio;
- MDF laccato colori RAL finitura opaca gofrata

**VERNICIATURA**

- Essenza: all'acqua in diverse mordenzature.
- Laccati: con vernice poliuretanicca.

**PANNELLO**

Okumè Spessore mm 15 (per le 2 ante mm19)

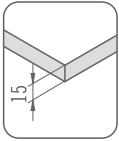

**PANNELLO**

MDF Spessore mm 18

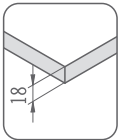

**MOD. 126**  
**Struttura**  
Okumè  
Tinto noce medio 45/B

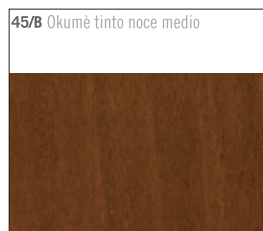

**N.B.**

Per l'essenza Okumè impiallacciato Rovere e Ciliegio, le misure che si possono realizzare sono:  
1 Anta misura max. cm 90x210,  
2 Ante, anta grande misura max. cm 90x210.

I colori e le venature dei legni sono da ritenersi indicativi. Consultare la "Cartella rivestimenti".



# OBELIX OMNIA

RIVESTIMENTI PANTOGRAFATI



**MOD. 121**  
Struttura MDF laccato 43/1013



**MOD. 126**  
Struttura Okumè tinto noce medio 45/B



**MOD. 132**  
Struttura Okumè tinto ciliegio 47

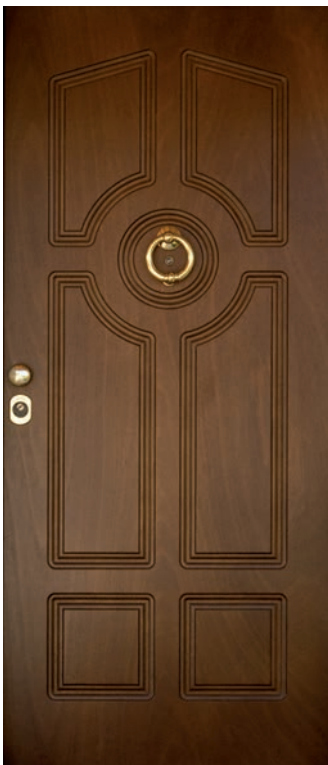

**MOD. 133**  
Struttura Okumè tinto noce scuro 45/C



**MOD. 136**  
Struttura MDF laccato 43/3031



**MOD. 137**  
Struttura MDF laccato 43/4007



**OBELIX OMNIA**  
RIVESTIMENTI PANTOGRAFATI



**MOD. 140**  
Struttura Okumè Essenza Ciliegio leggermente tinto 7

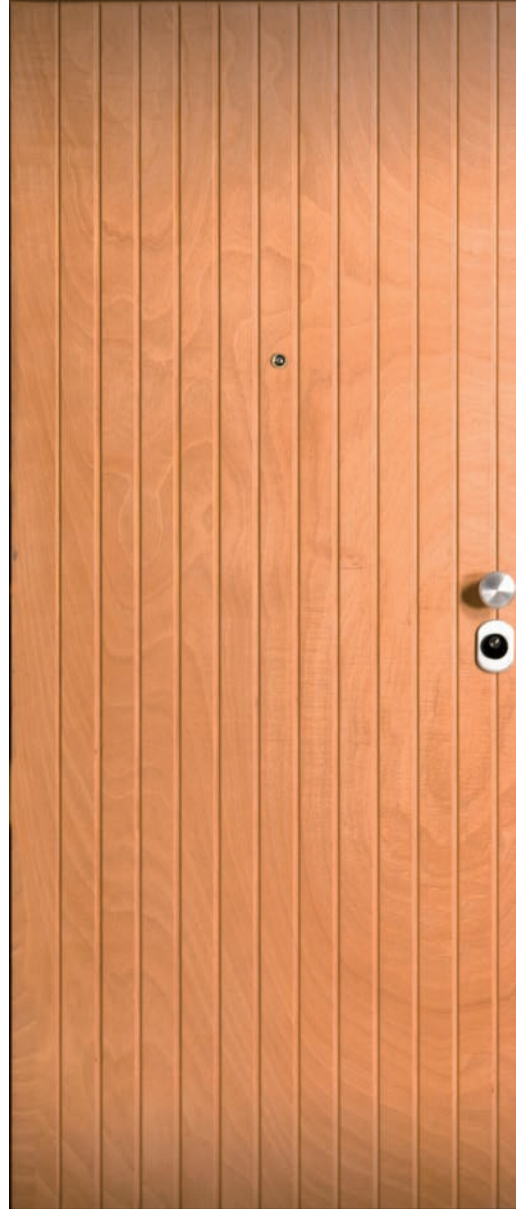

**MOD. 187**  
Struttura Okumè naturale leggermente tinto 44



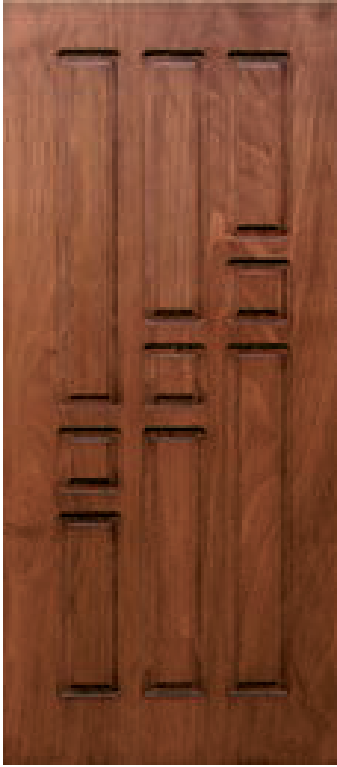

**MOD. 105**  
Struttura Okumè tinto mogano medio 46



**MOD. 106**  
Struttura Okumè naturale leggermente tinto 44



**MOD. 107**  
Struttura MDF laccato 43/9010



**MOD. 112**  
Struttura MDF laccato 43/5018



**MOD. 118**  
Struttura Okumè  
Essenza Ciliegio leggermente tinto 7



**MOD. 119**  
Struttura MDF laccato 43/6005



# OBELIX OMNIA

RIVESTIMENTI PANTOGRAFATI





**MOD. 114**  
Struttura Okumè tinto noce scuro 45/C



**MOD. 117**  
Struttura Okumè tinto noce medio 45/B



**MOD. 128**  
Struttura Okumè tinto ciliegio 47



**MOD. 129**  
Struttura MDF laccato 43/9010



**MOD. 131**  
Struttura MDF laccato 43/6005



**MOD. 139**  
Struttura Okumè tinto noce scuro 45/C  
inserti vetro fuso





**MOD. 134**  
Struttura MDF laccato 43/9010



**MOD. 155**  
Struttura Okumè tinto ciliegio 47

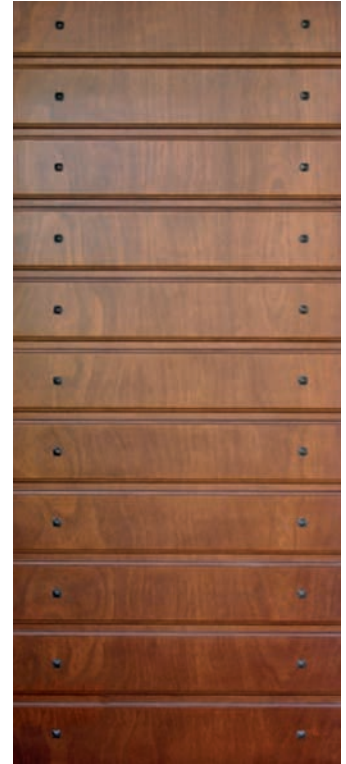

**MOD. 156**  
Struttura Okumè tinto noce scuro 45/C  
con chiodi



**MOD. 157**  
Struttura Okumè tinto noce medio 45/B

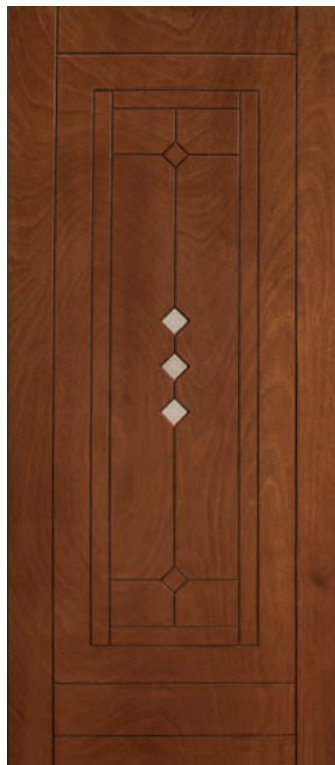

**MOD. 158**  
Struttura Okumè tinto noce medio 45/B  
inserti in acciaio inox



**MOD. 159**  
Struttura Okumè tinto ciliegio 47  
inserti in acciaio inox



# OBELIX OMNIA

RIVESTIMENTI PANTOGRAFATI



**MOD. 160**  
Struttura Okumè tinto noce scuro 45/C  
inserti acciaio inox

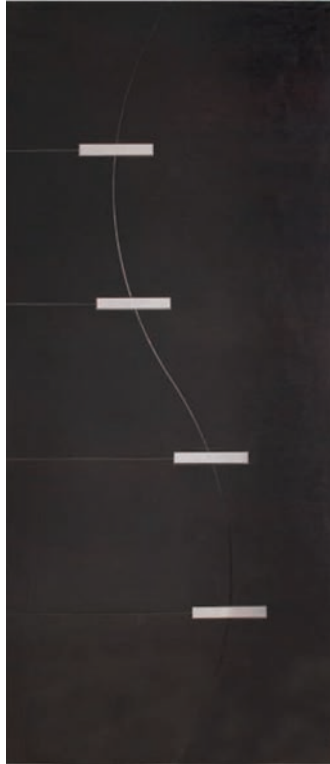

**MOD. 161**  
Struttura Okumè  
Essenza Rovere tinto wengè 11  
inserti acciaio inox



**MOD. 162**  
Struttura Okumè tinto ciliegio 47  
inserti acciaio inox



**MOD. 163**  
Struttura Okumè tinto mogano medio 46



**MOD. 164**  
Struttura Okumè tinto ciliegio 47  
inserti vetro fuso



**MOD. 165**  
Struttura Okumè tinto ciliegio 47  
inserti vetro fuso



**OBELIX OMNIA**  
RIVESTIMENTI PANTOGRAFATI



**MOD. 104**  
Struttura Okumè tinto mogano medio 46



**MOD. 166**  
Struttura Okumè tinto ciliegio 47  
inserti in vetro fuso



**MOD. 167**  
Struttura Okumè tinto ciliegio 47  
inserti in legno



**MOD. 168**  
Struttura Okumè tinto noce scuro 45/C  
inserti in legno



**MOD. 172**  
Struttura Okumè tinto ciliegio 47





# OBELIX OMNIA

RIVESTIMENTI PANTOGRAFATI



**MOD. 108**  
Struttura Okumè tinto noce chiaro 45/A

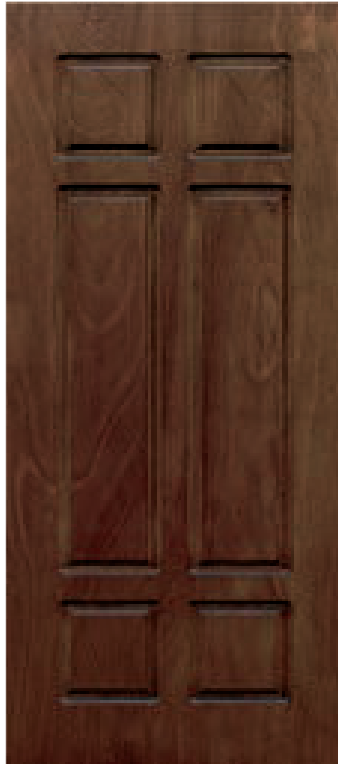

**MOD. 116**  
Struttura Okumè tinto noce scuro 45/C



**MOD. 124**  
Struttura Okumè tinto noce scuro 45/C



**MOD. 130**  
Struttura Okumè tinto noce medio 45/B



**MOD. 173**  
Struttura Okumè tinto ciliegio 47



**MOD. 174**  
Struttura Okumè tinto noce medio 45/B



**MOD. 127**  
Struttura Okumè tinto ciliegio 47



**MOD. 175**  
Struttura Okumè tinto tinto noce scuro 45/C



**MOD. 176**  
Struttura Okumè tinto ciliegio 47



**MOD. 177**  
Struttura Okumè tinto noce medio 45/B



**MOD. 178**  
Struttura Okumè tinto ciliegio 47

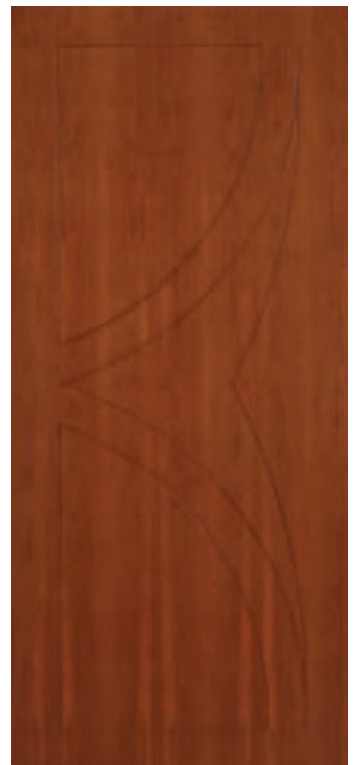

**MOD. 179**  
Struttura Okumè tinto ciliegio 47





# OBELIX OMNIA

RIVESTIMENTI PANTOGRAFATI



**MOD. 109**  
Struttura MDF laccato 43/6005



**MOD. 180**  
Struttura Okumè tinto noce chiaro 45/A



**MOD. 181**  
Struttura Okumè tinto noce scuro 45/C



**MOD. 182**  
Struttura Okumè tinto noce scuro 45/C



**MOD. 183**  
Struttura Okumè tinto noce medio 45/B



**MOD. 184**  
Struttura Okumè tinto ciliegio 47

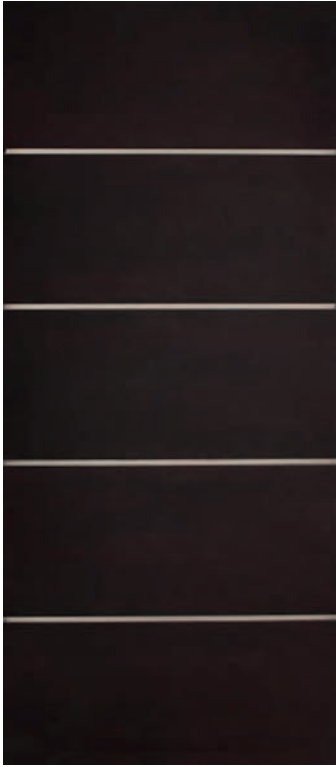

**MOD. 149**  
Struttura Okumè  
Essenza Rovere tinto wengè 11  
inserti acciaio inox



**MOD. 150**  
Struttura Okumè tinto ciliegio 47



**MOD. 151**  
Struttura Okumè  
Essenza Ciliegio leggermente tinto 7



**MOD. 152**  
Struttura Okumè  
Essenza Rovere sbiancato 10  
inserti acciaio inox



**MOD. 153**  
Struttura Okumè  
Essenza Ciliegio leggermente tinto  
inserti acciaio inox + vetro

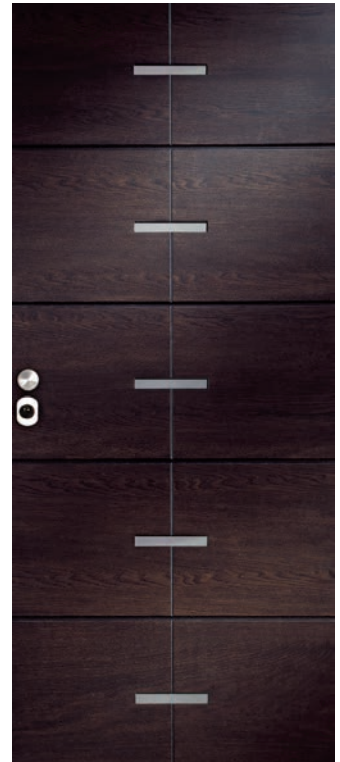

**MOD. 154**  
Struttura Okumè  
Essenza Rovere tinto wengè 11  
inserti acciaio inox



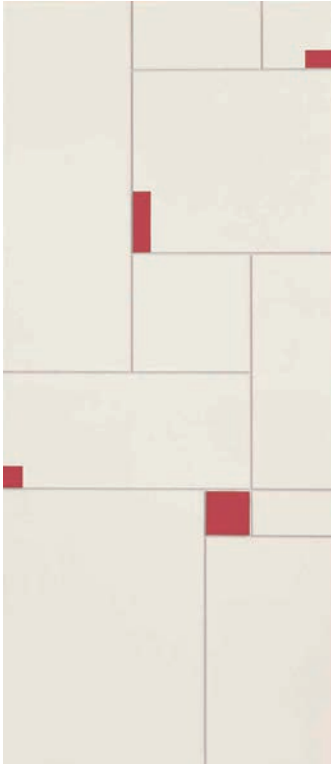

**MOD. 188**  
Struttura MDF laccato 43/9010  
inserti alluminio rosso elettrico

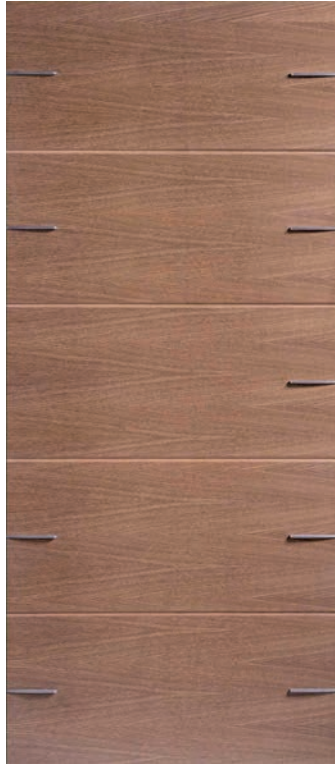

**MOD. 189**  
Struttura Okumè  
Essenza Rovere naturale leggermente tinto 8  
inserti acciaio inox



**MOD. 190**  
Struttura Okumè  
Essenza Rovere naturale leggermente tinto 8  
inserti acciaio inox



**MOD. 191**  
Struttura Okumè tinto ciliegio 47  
inserti acciaio inox + vetro



**MOD. 192**  
Struttura Okumè tinto noce medio 45/B  
con vetro



**MOD. 196**  
Struttura MDF  
Essenza RAL 4006 (viola), RAL 9018 (grigio) lucido



**MOD. 194**  
Struttura MDF impiallacciato  
Essenza Rovere tinto wengè 11  
Particolare lavorazione centrale ondulata.

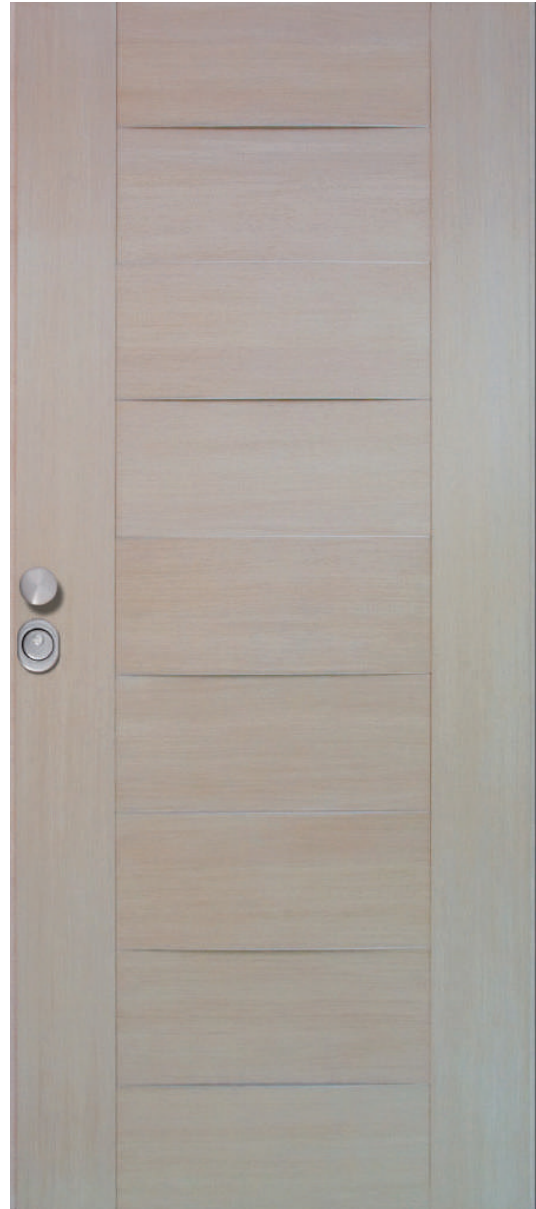

**MOD. 195**  
Struttura MDF impiallacciato  
Essenza Rovere sbiancato 10  
Inserti cromo satinati



# OBELIX OMNIA

DISEGNI RIVESTIMENTI PANTOGRAFATI



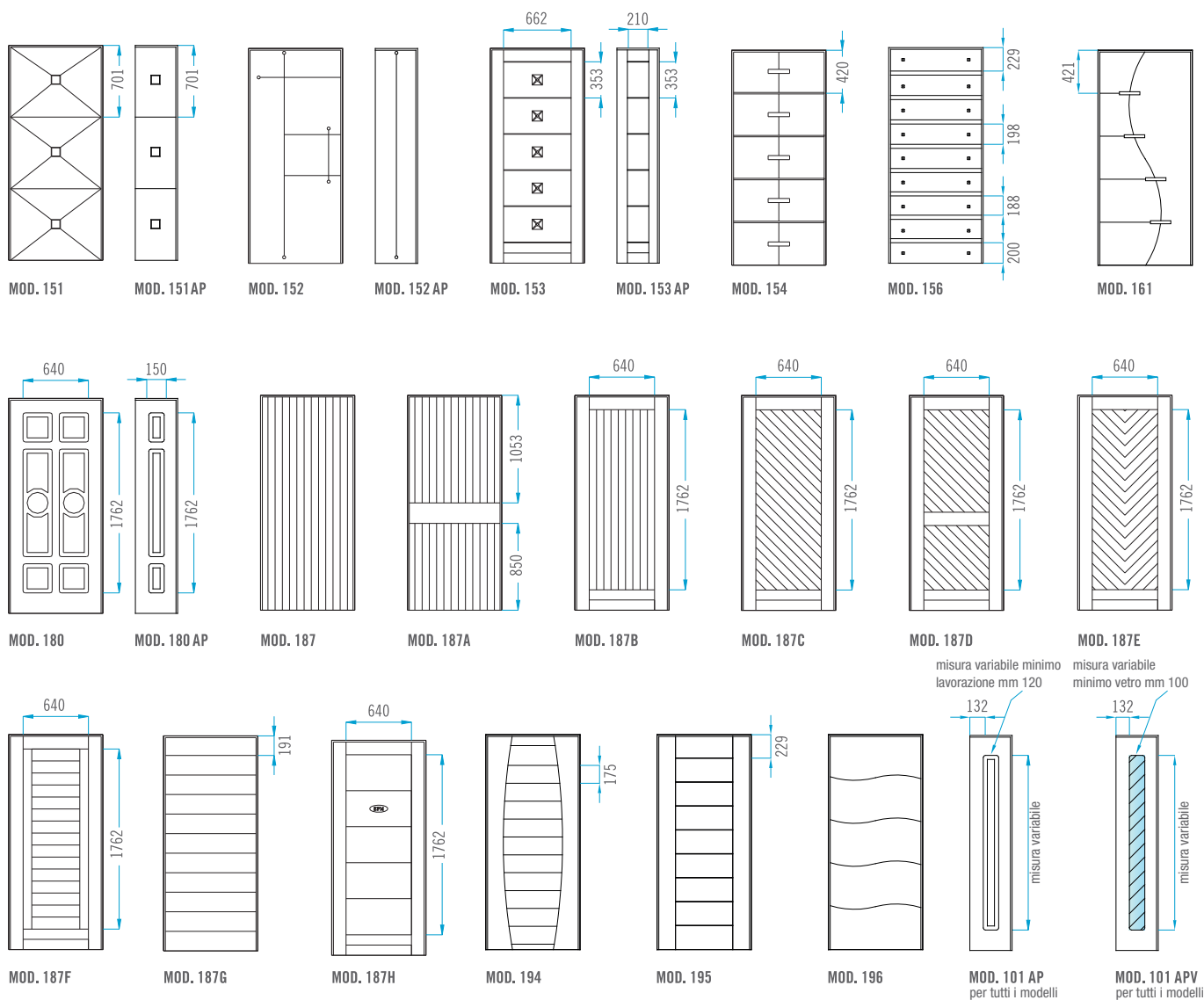

misura variabile minimo lavorazione mm 120  
misura variabile minimo vetro mm 100

**FASCIA DI RISPETTO**

- Anta principale cieca **mm 110**
- Anta principale finestrata **mm 195**
- Anta secondaria cieca **mm 70**
- Anta secondaria finestrata **mm 110**

**MISURE MINIME REALIZZABILI PER SINGOLO MODELLO**

	cm 50	cm 60	cm 65	cm 70	cm 80
	128	101V	114	110	194
	129	101V1	161	125	195
	134	104V		131	
	137	117		151	
	139	121		161	
	140	126			
	149	127			
	150	129V			
	152	133			
	153	136V			
	154	180			
	156	196			
	187				

187 A-B-C-D-E-F-G-H





 **FERRARO**  
LIVING®

VICTORIA



**STRUTTURA**

- legno massello rovere, iroko, noce daniela, ciliegio, pino, douglas;
- massello in listellare di pioppo impiallacciato ciliegio, rovere, noce nazionale;
- Mdf laccato colori RAL finitura opaca gofrata

**VERNICIATURA**

Essenza: all'acqua in diverse mordenzature.  
MDF: vernici poliuretaniche.

**PANNELLO**

Essenza: spessore mm 20

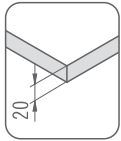

**PANNELLO**

MDF spessore mm 18

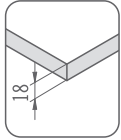

**MOD. 202**  
**Struttura**  
Rovere tinto noce  
medio 31/B

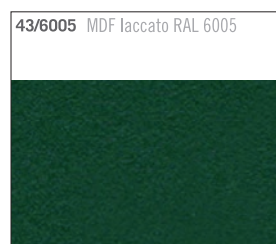
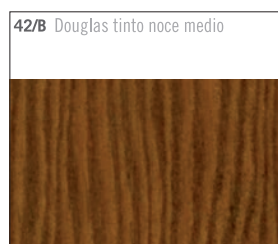
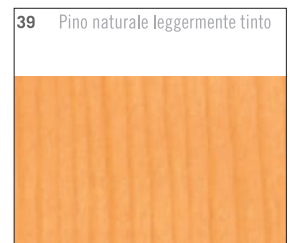
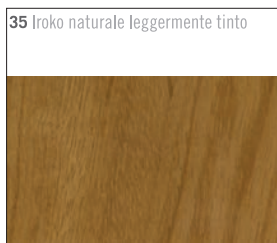
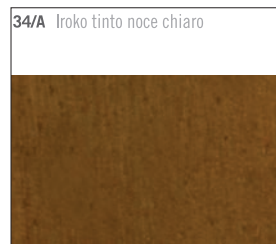
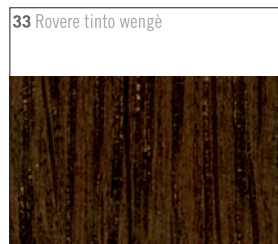
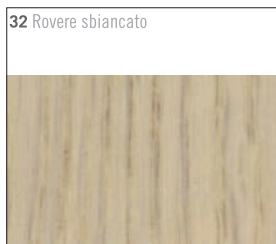
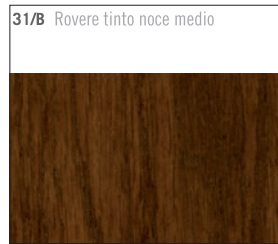
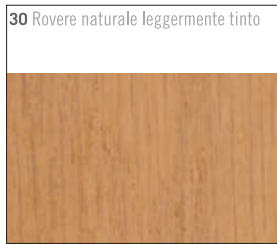

**N.B.**  
I colori e le venature dei legni sono da ritenersi indicativi. Consultare la "Cartella rivestimenti".





# OBELIX VICTORIA

RIVESTIMENTI MASSELLO



**MOD. 201**  
Struttura Noce daniela naturale 37



**MOD. 202**  
Struttura Rovere tinto noce medio 31/B



**MOD. 206**  
Struttura Rovere tinto noce medio 31/B



**MOD. 209**  
Struttura Douglas naturale leggermente tinto 41



**MOD. 213**  
Struttura Iroko tinto noce medio 34/B



**MOD. 217**  
Struttura Rovere naturale leggermente tinto 30





# OBELIX VICTORIA

RIVESTIMENTI MASSELLO



**MOD. 203**  
Struttura Pino noce tinto medio 40/B

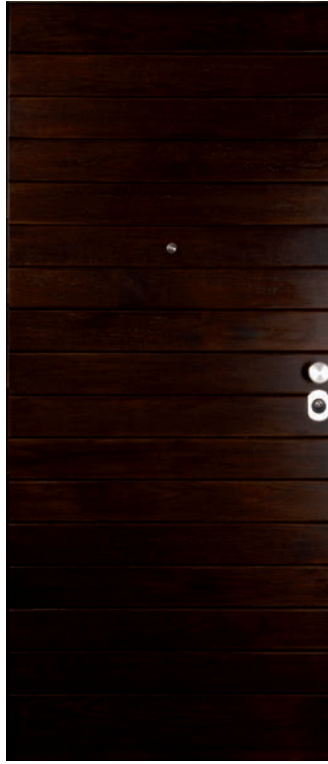

**MOD. 205**  
Struttura Rovere tinto wengè 33



**MOD. 214**  
Struttura Rovere tinto noce medio 31/B



**MOD. 216**  
Struttura Iroko tinto noce medio 34/B

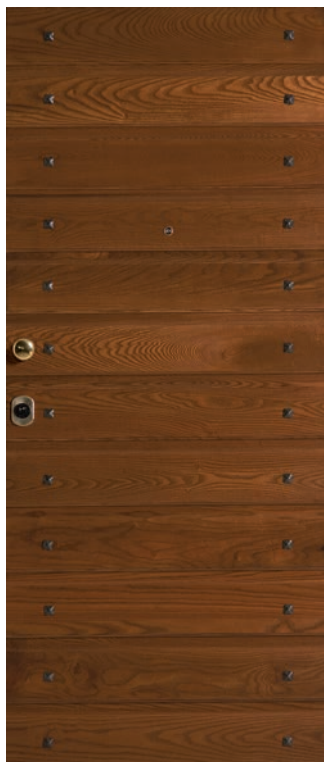

**MOD. 222**  
Struttura Rovere tinto noce medio 31/B con chiodi



**MOD. 223**  
Struttura Rovere tinto noce medio 31/B



**OBELIX VICTORIA**  
RIVESTIMENTI MASSELLO



34



**MOD. 207**  
Struttura Iroko tinto noce chiaro 34/A



**MOD. 208**  
Struttura Ciliegio naturale leggermente tinto 38



# OBELIX VICTORIA

RIVESTIMENTI MASSELLO



**MOD. 212**  
Struttura Iroko naturale leggermente tinto 35



**MOD. 210**  
Struttura Ciliegio naturale leggermente tinto 38



**MOD. 211**  
Struttura Ciliegio naturale leggermente tinto 38



**MOD. 249**  
Struttura Iroko naturale leggermente tinto 35





# OBELIX VICTORIA

RIVESTIMENTI MASSELLO



**MOD. 250**  
Struttura Iroko naturale  
leggermente tinto 35

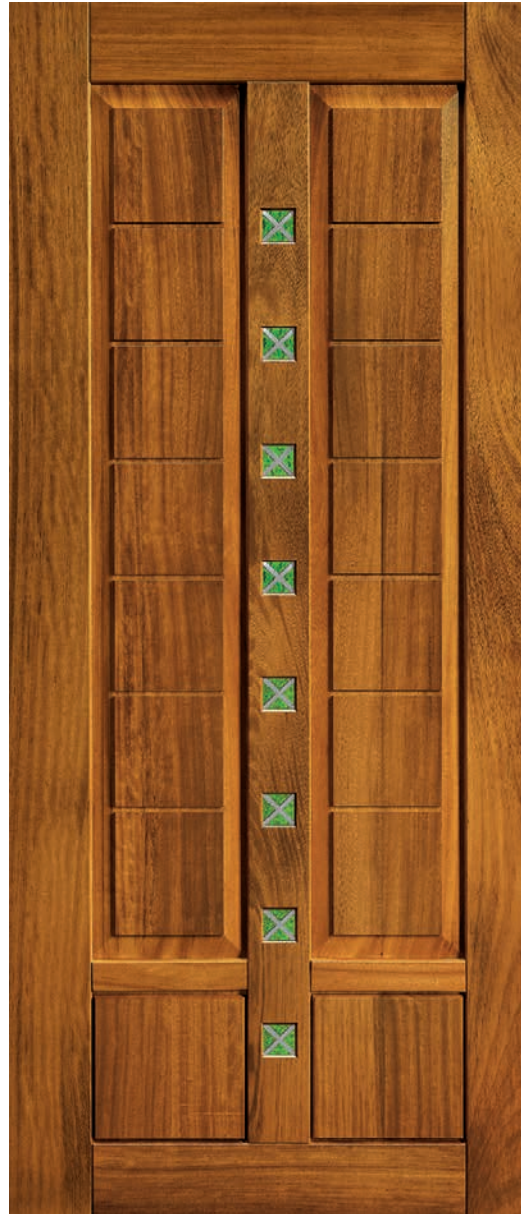

**MOD. 251**  
Struttura Iroko naturale  
leggermente tinto 35 con vetro





**OBELIX VICTORIA**  
RIVESTIMENTI MASSELLO



**MOD. 252**  
Struttura Ciliegio naturale  
leggermente tinto 38



**MOD. 253**  
Struttura Ciliegio naturale  
leggermente tinto 35



# OBELIX VICTORIA

RIVESTIMENTI MASSELLO



**MOD. 218**  
Struttura MDF laccato 43/6005  
Essenza Pioppo con bugna ciliegio



**MOD. 224**  
Struttura MDF laccato 43/6005  
Essenza Pioppo con bugna ciliegio



**MOD. 228**  
Struttura Noce nazionale 6  
Essenza Pioppo



**MOD. 229**  
Struttura Noce nazionale 6  
Essenza Pioppo



**MOD. 230**  
Struttura Iroko naturale leggermente tinto 35



**MOD. 231**  
Struttura Ciliegio naturale leggermente tinto 38





**MOD. 232**  
Struttura Iroko naturale leggermente tinto 35



**MOD. 233**  
Struttura Ciliegio naturale leggermente tinto 38



**MOD. 234**  
Struttura Rovere tinto noce chiaro 31/A



**MOD. 235**  
Struttura Iroko naturale leggermente tinto 35



**MOD. 236**  
Struttura Rovere tinto noce chiaro 31/A



**MOD. 237**  
Struttura Ciliegio naturale leggermente tinto 38



**MOD. 238**  
Struttura Iroko tinto noce chiaro 34/A



**MOD. 239**  
Struttura Iroko tinto noce chiaro 34/A



**MOD. 240**  
Struttura Ciliegio naturale leggermente tinto 38



**MOD. 241**  
Struttura Iroko tinto noce chiaro 34/A



**MOD. 243**  
Struttura Rovere tinto noce medio 31/B



**MOD. 245**  
Struttura Pino tinto noce medio 40/B



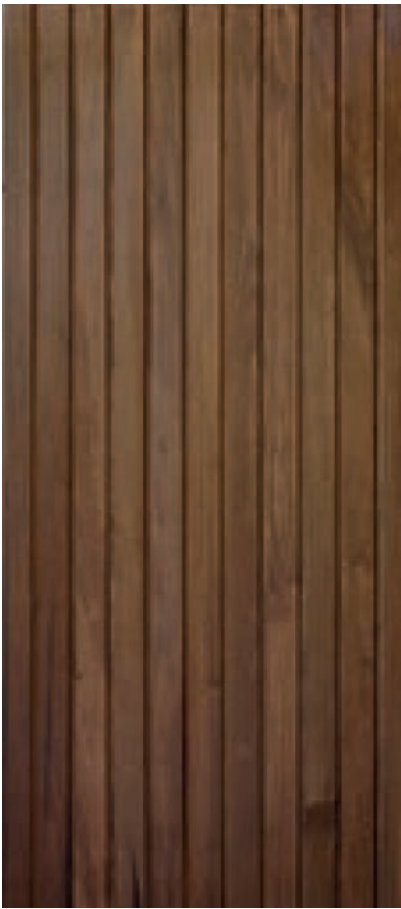

**MOD. 246**  
Struttura Rovere tinto noce medio 31/B



**MOD. 247**  
Struttura Rovere tinto noce medio 31/B



**MOD. 248**  
Struttura Rovere tinto wengè 33  
Inseri Acciaio



# OBELIX VICTORIA

DISEGNI RIVESTIMENTI MASSELLO

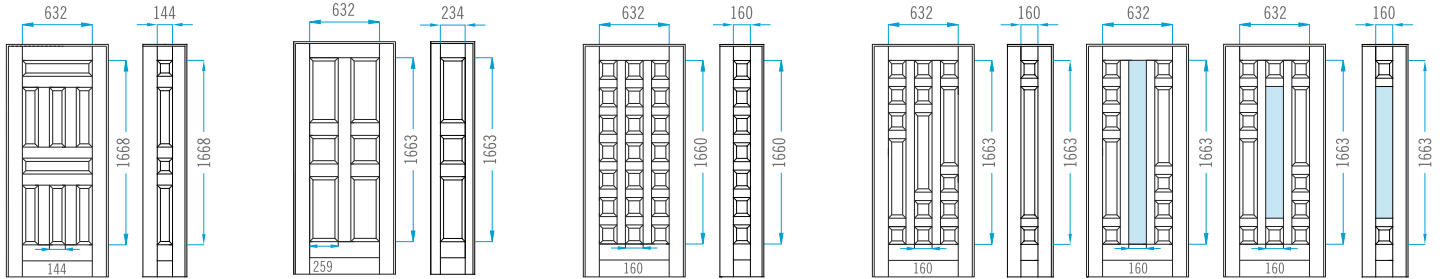

MOD. 201    MOD. 201AP    MOD. 215    MOD. 215AP    MOD. 203    MOD. 203AP    MOD. 206    MOD. 206AP    MOD. 206V    MOD. 206V1    MOD. 206V1AP

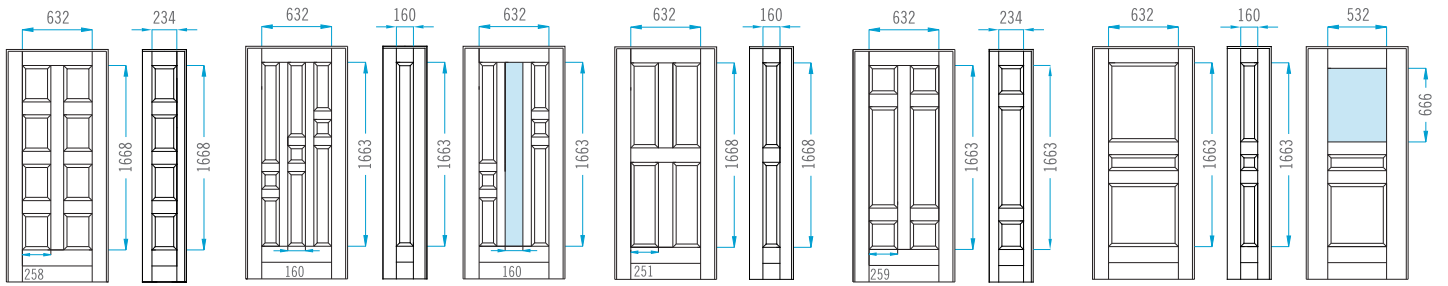

MOD. 209    MOD. 209AP    MOD. 213    MOD. 213AP    MOD. 213V    MOD. 214    MOD. 214AP    MOD. 202    MOD. 202AP    MOD. 216    MOD. 216AP    MOD. 216V

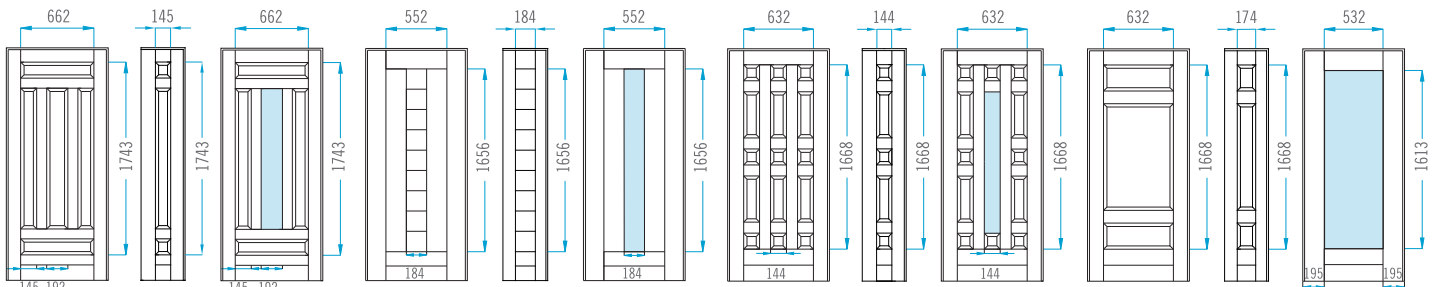

MOD. 217    MOD. 217AP    MOD. 217V    MOD. 218    MOD. 218AP    MOD. 218V    MOD. 219    MOD. 219AP    MOD. 219V    MOD. 220    MOD. 220AP    MOD. 220V

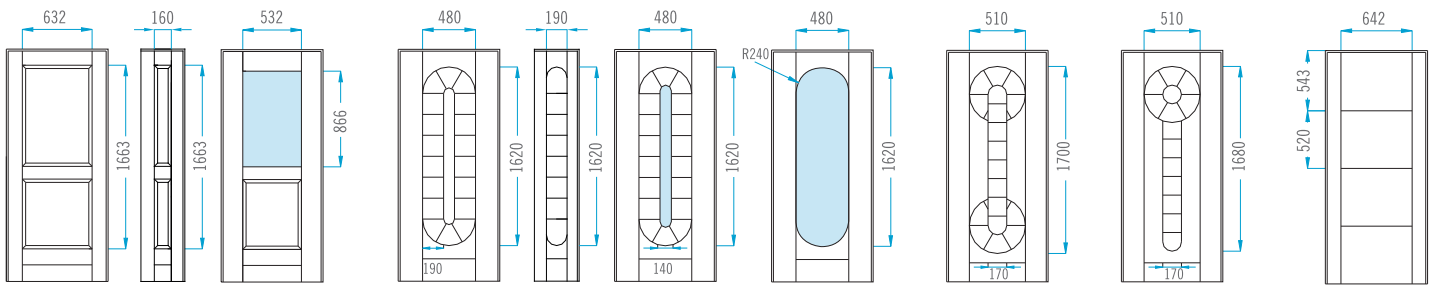

MOD. 221    MOD. 221AP    MOD. 221V    MOD. 224    MOD. 224AP    MOD. 224V    MOD. 224V1    MOD. 226    MOD. 227    MOD. 228



# OBELIX VICTORIA

DISEGNI RIVESTIMENTI MASSELLO

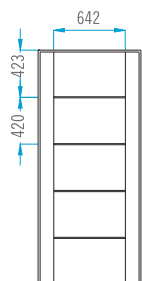

MOD. 229

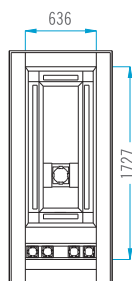

MOD. 230

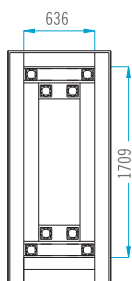

MOD. 231



MOD. 232



MOD. 233

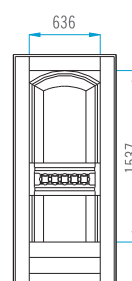

MOD. 234

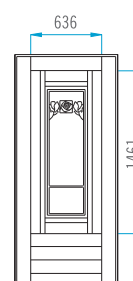

MOD. 235

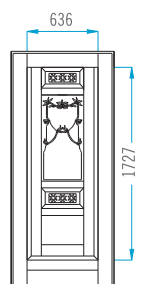

MOD. 236

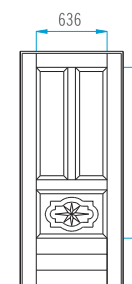

MOD. 237

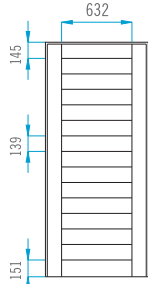

MOD. 238

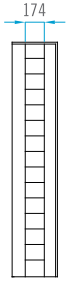

MOD. 238AP

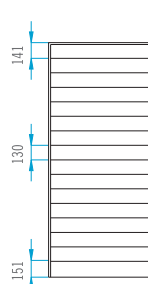

MOD. 239



MOD. 239AP

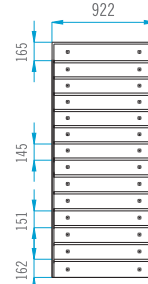

MOD. 240



MOD. 240AP

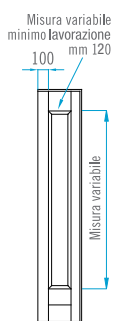

MOD. 110 AP  
per tutti i modelli

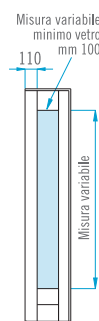

MOD. 110 VAP  
per tutti i modelli

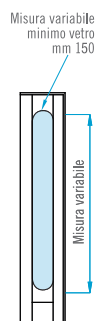

MOD. 224V1AP  
per tutti i modelli

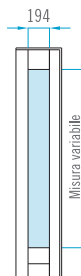

MOD. 218VAP  
per tutti i modelli

## FASCIA DI RISPETTO

- Anta principale cieca **mm 110**
- Anta principale finestrata **mm 195**
- Anta secondaria cieca **mm 70**
- Anta secondaria finestrata **mm 110**

## MISURE MINIME REALIZZABILI PER SINGOLO MODELLO

cm 50	cm 60	cm 77	cm 80	cm 82	cm 85	cm 86	cm 88	cm 90
216	202	201	231	230	232	237	236	233
220	209	203			234			235
221	214	206						
228	215	213						
229	220	217						
238		218						
239		219						
240		224						
		227						





 **FERRARO**  
LIVING®

WOOD



# OBELIX WOOD

RIVESTIMENTI LEGNO MASSELLO ANTICATO

## STRUTTURA

· *Legno massello anticato rovere e castagno*

## VERNICIATURA

· *Essenza: all'acqua nelle mordenzature tinto noce chiaro e medio*

## PANNELLO

· *Spessore mm 20.*

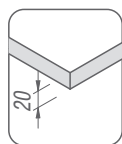

**MOD. 202**  
**Struttura**  
Rovere tinto  
noce chiaro  
Con chiodi  
in legno



**MOD. 202**  
**Struttura** Rovere tinto noce chiaro  
Con chiodi in legno



**MOD. 214**  
**Struttura** Rovere tinto noce medio  
Con chiodi in legno

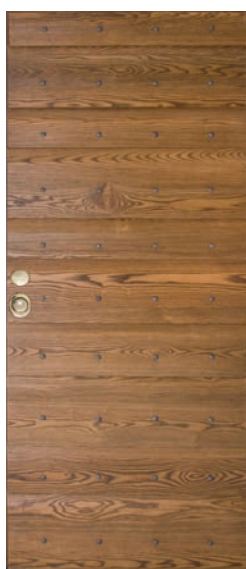

**MOD. 240**  
**Struttura** Castagno tinto noce medio  
Con chiodi in ferro forgiato

Asciato e spazzolato a mano.

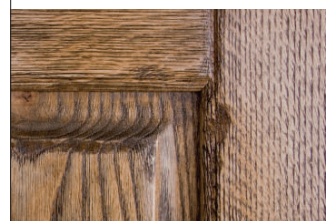

Asciato e spazzolato a mano.  
Chiodi in legno.

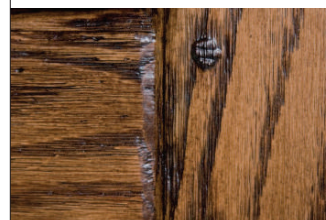

Asciato e spazzolato a mano.  
Chiodi in ferro forgiato. (Solo MOD.240)





# OBELIX WOOD

RIVESTIMENTI LEGNO MASSELLO ANTICATO

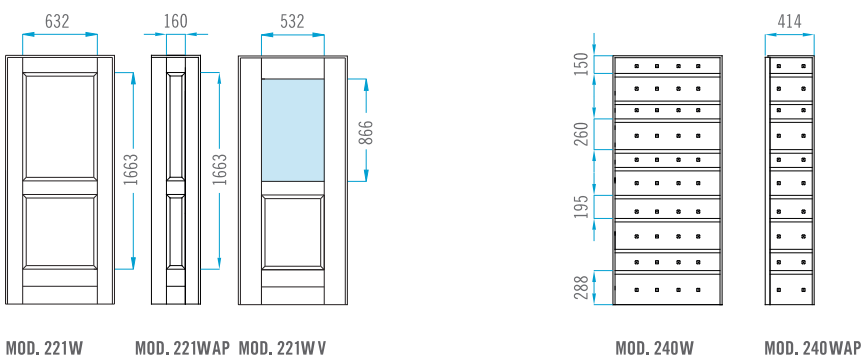
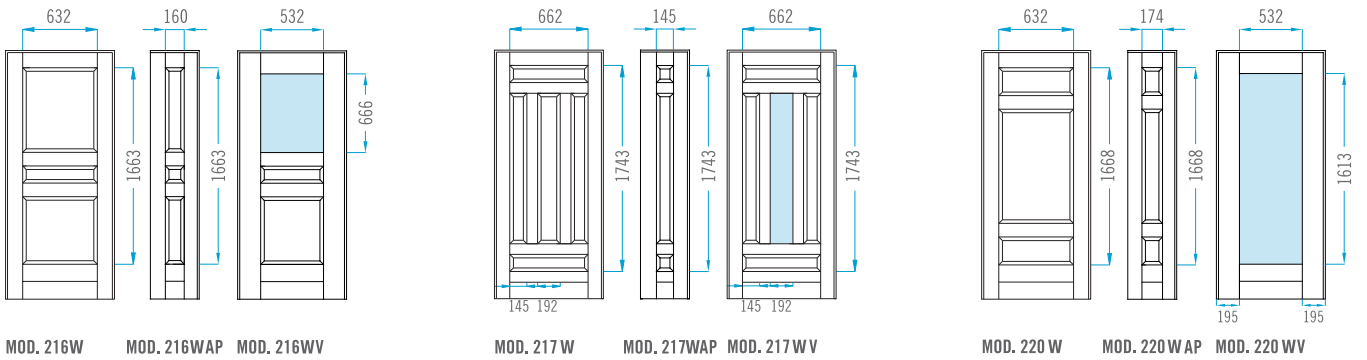
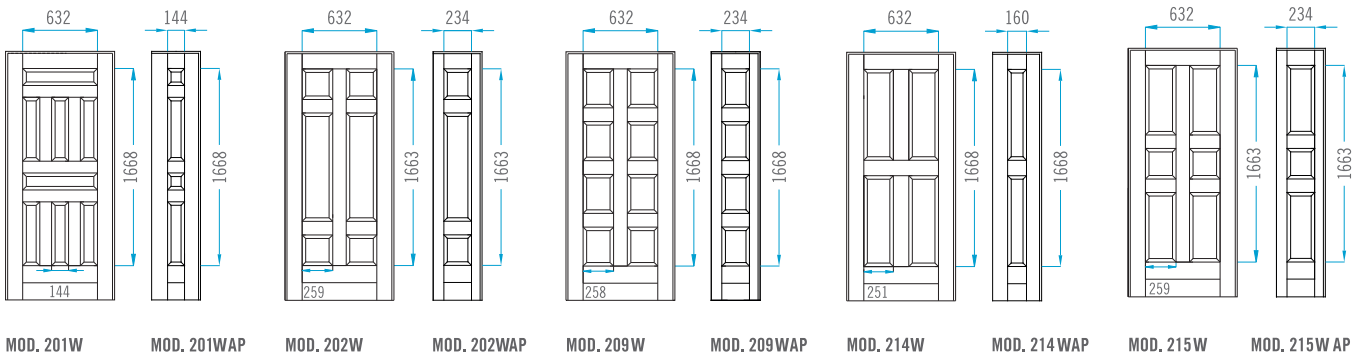

### FASCIA DI RISPETTO

- Anta principale cieca **mm 110**
- Anta principale finestrata **mm 195**
- Anta secondaria cieca **mm 70**
- Anta secondaria finestrata **mm 110**







ARCADIA STYLE





# OBELIX ARCADIA

RIVESTIMENTI ALLUMINIO

## STRUTTURA

- in alluminio con isolamento Pirall.

## VERNICIATURA

- a polveri poliesteri.

## COLORE

- laccati RAL finitura opaca, laccati RAL finitura lucida,  
Renolit pvc colori legno, verniciati legno.

## PANNELLO

Spessore mm 7.

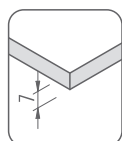

## MOD. MIRANDA KB

Struttura

Alluminio colore laccato RAL 60/1001

## LACCATI

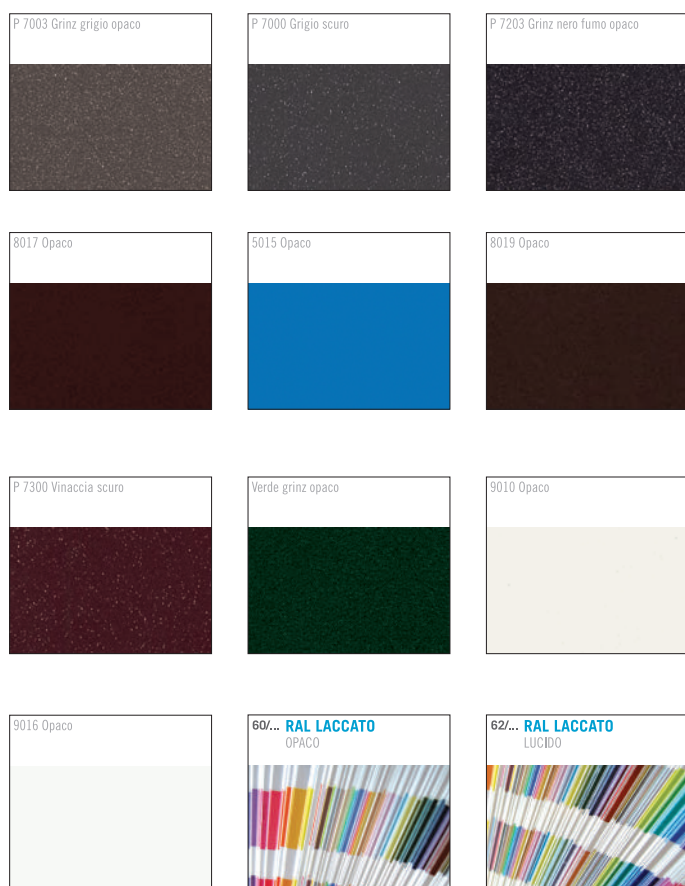

## RENOLIT

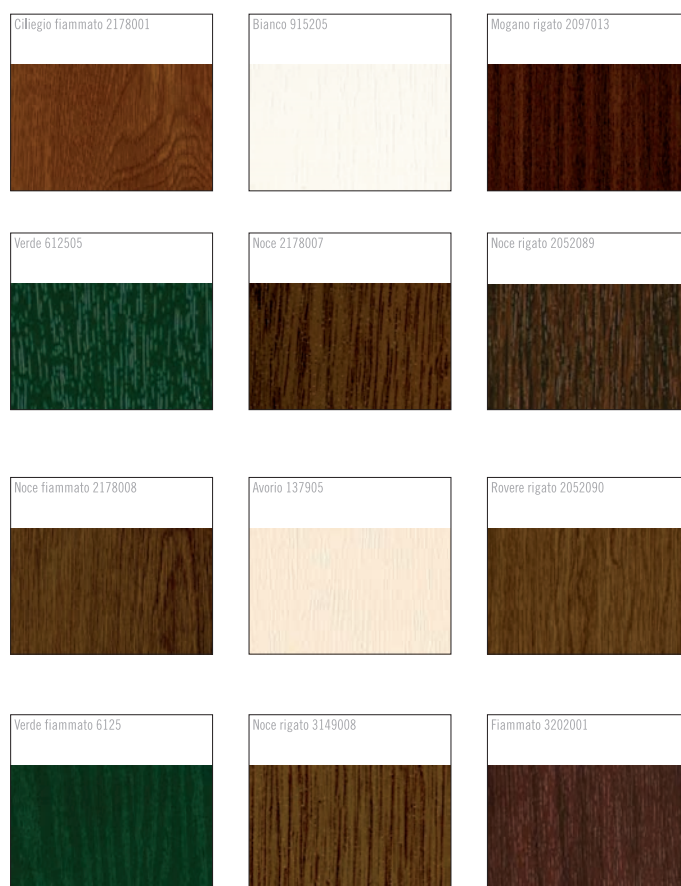

IMMAGINI: Arcadia Style e Arcadia Classic di proprietà Royal Pat srl.



# OBELIX ARCADIA

RIVESTIMENTI ALLUMINIO LINEA STYLE



MOD. ALGENIB-XC1



MOD. AURIGA-XC1



MOD. CASSIOPEA-X



MOD. CASSIOPEA-X1



MOD. DREAMIX



MOD. DREAM-X3



MOD. ECHO-X1



MOD. ELISIR-X1



MOD. ELLISSE-X



MOD. ELLISSE-X1



MOD. KLIO-X1



MOD. MOON-X



MOD. MOON-X1





# OBELIX ARCADIA

RIVESTIMENTI ALLUMINIO LINEA STYLE



MOD. TRIANGOLO-X1



MOD. VELE-X



MOD. VELE-X2



MOD. OBLÒ-X



MOD. OBLÒ-X1



MOD. ONDA-XD



MOD. ONDA-XD1



MOD. QUADRA-XD



MOD. QUADRA-XD1



MOD. ROTARY-X



MOD. STILUS-XV1



MOD. TRIANGOLO-X









 **FERRARO**  
LIVING®

ARCADIA CLASSIC



# OBELIX ARCADIA

RIVESTIMENTI ALLUMINIO LINEA CLASSIC



MOD. CASTORE-K



MOD. CASTORE-K1



MOD. DORADO-K



MOD. DORADO-K1



MOD. ECHO-K



MOD. ELISIR-K



MOD. ELISIR-KB



MOD. ERIDANO-K



MOD. ERIDANO-K2



MOD. ERIDANO-K6



MOD. ERMES-K



MOD. ERMES-K1



MOD. GEMINI-K



MOD. GEMINI-K1



MOD. GEMMA-K



MOD. GEMMA-K1



MOD. GEO-K



MOD. GEO-K1



MOD. IKARO-K



MOD. IKARO-K1



MOD. IKARO-KB1



MOD. IKARO-KC



MOD. IRIS-K



MOD. IRIS-K1



MOD. IRIS-K3



MOD. IRIS-KC1



MOD. CALIPSO-KD



MOD. KLIO-KB



MOD. KLIO-KD



MOD. LIBRA-K



# OBELIX ARCADIA

RIVESTIMENTI ALLUMINIO LINEA CLASSIC



MOD. ABACO-K



MOD. ALDEBARAN-K



MOD. ALDEBARAN-K2



MOD. ALEX-K



MOD. ALFA-K



MOD. ALFA-K6



MOD. ALFA-K10



MOD. ALFAIR-K



MOD. ALFAIR-K2



MOD. ALGENIB-K



MOD. ALGENIB-KB



MOD. ALGENIB-KC



MOD. ALGENIB-KD



MOD. ALGENIB-KE



MOD. ALGENIB-KE1



MOD. ALIZAR-K



MOD. ANTARES-K



MOD. ANTARES-KD



MOD. ANTARES-KD1



MOD. ARIES-K



MOD. ASTRA-K



MOD. AURIGA-K



MOD. AURIGA-KB1



MOD. BASILEO-K



MOD. BASILEO-K1



MOD. BELLATRIX-K



MOD. BELLATRIX-K1



MOD. BELLATRIX-K3



MOD. BELLATRIX-K5



MOD. CASSIOPEA-K





# OBELIX ARCADIA

RIVESTIMENTI ALLUMINIO LINEA CLASSIC



MOD. LIBRA-K1



MOD. MINERVA-K



MOD. MINERVA-K1



MOD. MIRA-K



MOD. MIRA-K2



MOD. MIRA-K4



MOD. MIRA-K6



MOD. MIRANDA-K



MOD. MIRANDA-K1

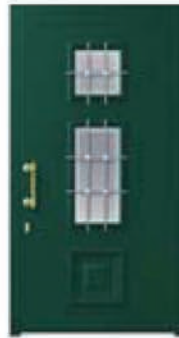

MOD. MIRANDA-K2



MOD. MIRANDA-K3



MOD. MIRANDA-KB



MOD. MIRANDA-KB1



MOD. MIZAR-K



MOD. MIZAR-K2



MOD. NYSA-K



MOD. NYSA-K1



MOD. PALLADIO-K



MOD. PALLADIO-K1



MOD. PEGASO-K



MOD. PEGASO-K4



MOD. PEGASO-KB



MOD. PEGASO-KM



MOD. PERSEO-K



MOD. PERSEO-K1



MOD. POLARIS-K



MOD. POLARIS-K1



MOD. POLARIS-K2



MOD. QUASAR-K



MOD. QUASAR-K1



# OBELIX ARCADIA

RIVESTIMENTI ALLUMINIO LINEA CLASSIC



MOD. QUASAR-K3



MOD. REGOLO-KA



MOD. REGOLO-KA1



MOD. REGOLO-KB



MOD. REGOLO-KC



MOD. REGOLO-KD



MOD. REGOLO-KD1



MOD. RIGEL-K



MOD. RIGEL-K2



MOD. RIGEL-KB



MOD. RIGEL-KB1



MOD. SIRIO-K



MOD. SIRIO-K1



MOD. SIRIO-KC



MOD. SIRIO-KE



MOD. SPIGA-KD



MOD. SPIGA-KE



MOD. SPIGA-K1



MOD. SPIGA-KM



MOD. STILUS-K



MOD. STILUS-K1



MOD. TITANO-K



MOD. TITANO-K2



MOD. TRIADE-K



MOD. TRIADE-K1



MOD. TRIADE-KB



MOD. URANIA-K



MOD. VEGA-K4



MOD. VICTORIA-K



MOD. VICTORIA-K1





# OBELIX ARCADIA

DISEGNI RIVESTIMENTI ALLUMINIO LINEA CLASSIC

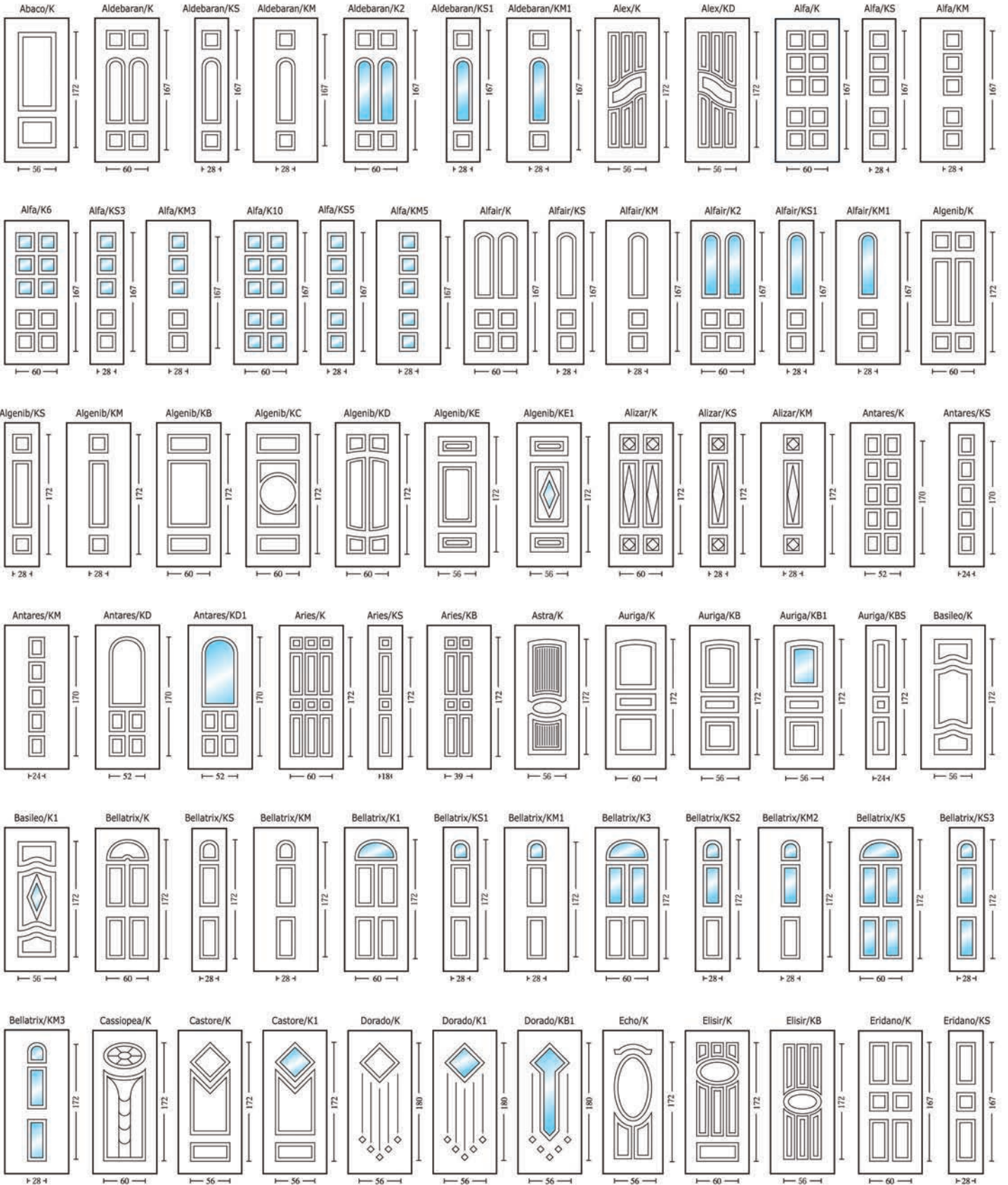

NOTE: Tutti i disegni sono per porte blindate di luce netta 90x210, cambiando le misure, i disegni avranno delle variazioni nelle proporzioni.





# OBELIX ARCADIA

DISEGNI RIVESTIMENTI ALLUMINIO LINEA CLASSIC

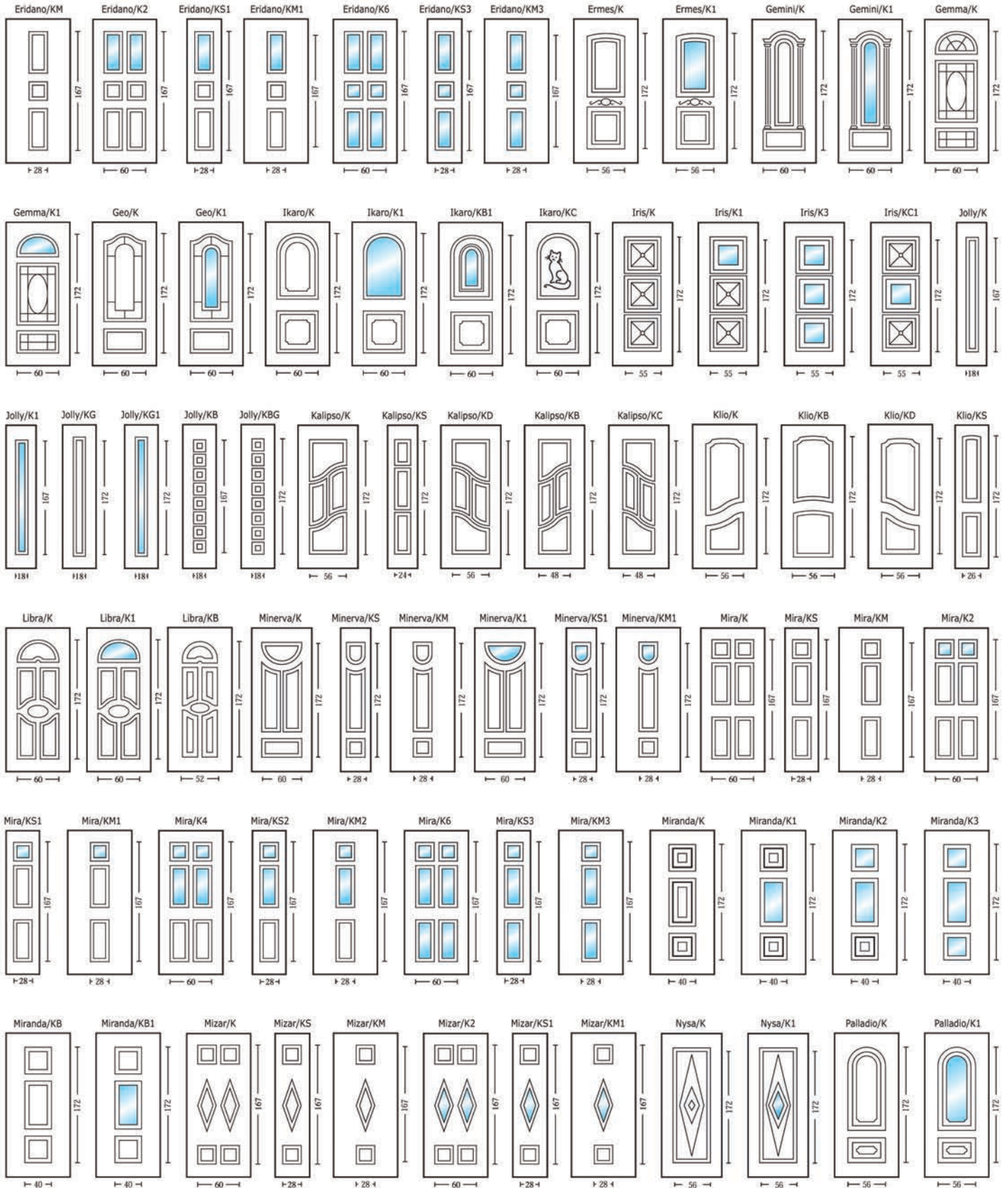

NOTE: Tutti i disegni sono per porte blindate di luce netta 90x210, cambiando le misure, i disegni avranno delle variazioni nelle proporzioni.



# OBELIX ARCADIA

DISEGNI RIVESTIMENTI ALLUMINIO LINEA CLASSIC

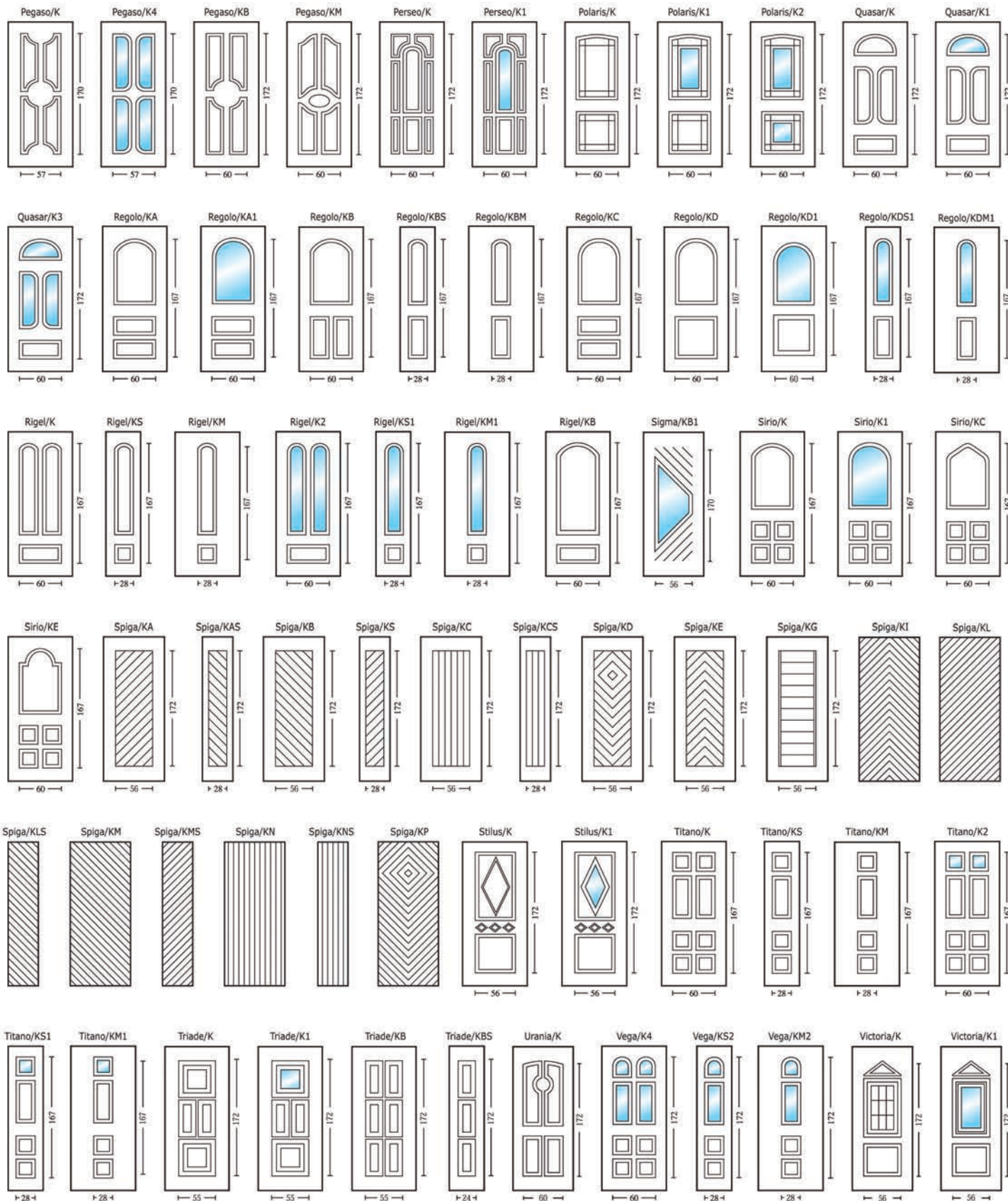

NOTE: Tutti i disegni sono per porte blindate di luce netta 90x210, cambiando le misure, i disegni avranno delle variazioni nelle proporzioni.



# ARCADIA ECO





# OBELIX ARCADIA

RIVESTIMENTI ALLUMINIO LINEA ECO

## STRUTTURA

- lastra in alluminio bugnato;
- laminato su supporto MDF controbilanciato.

## COLORE

- laccato Royal finitura lucida o su richiesta opaca;
- verniciato legno gamma Royal.

## PANNELLO

Spessore mm 7.

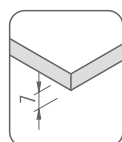

MOD. GORIZIA/1  
Struttura  
Alluminio  
laccato RAL 4007



## LACCATI



## RENOLIT





# OBELIX ARCADIA

DISEGNI RIVESTIMENTI ALLUMINIO LINEA ECO

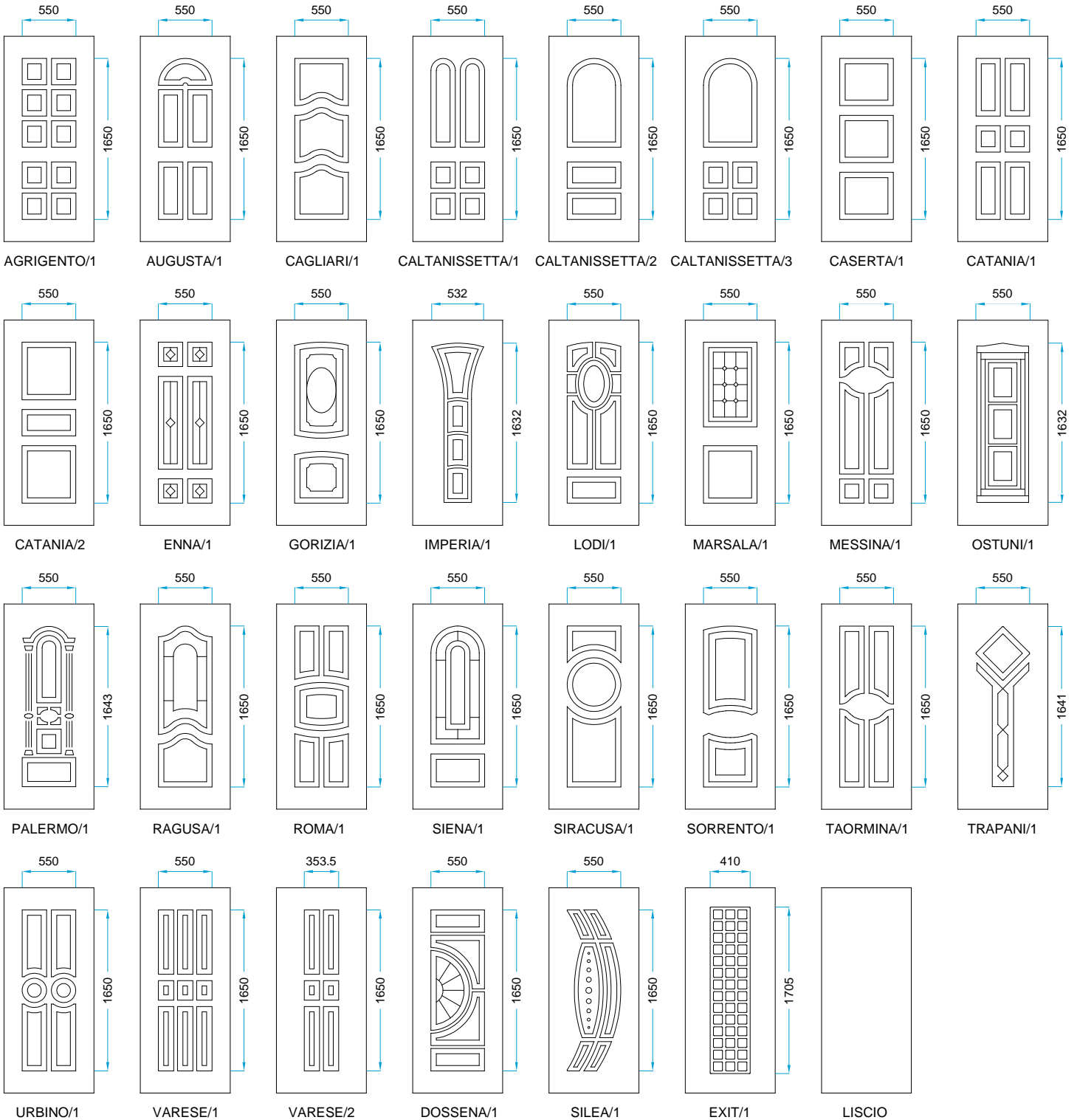

NOTE: Tutti i disegni sono per porte blindate di luce netta 80-85-90x210 ad un'anta.







 **FERRARO**  
LIVING®

ATENA



# OBELIX ATENA

RIVESTIMENTI PVC

## STRUTTURA

PVC su supporto HDF idrorepellente

## VERNICIATURA

Hormschuch PVC

## PANNELLO

Spessore mm 12.

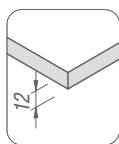

MOD.  
Q-087-V01+Q-201-V01  
Struttura  
PVC  
Colore  
436-5049 Grigio chiaro

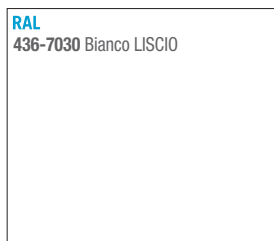
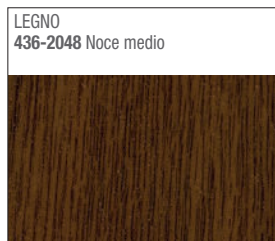
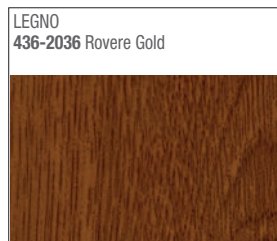

## FASCIA DI RISPETTO

- Anta principale cieca mm 110
- Anta principale finestrata mm 195
- Anta secondaria cieca mm 70
- Anta secondaria finestrata mm 110



**N.B.**  
Misura massima realizzabile per i  
pannelli in PVC sono:  
Anta grande cm 110x280;  
Anta piccola cm 55x280.



**OBELIX ATENA**  
RIVESTIMENTI PVC



**MOD. P-043**  
Struttura PVC Noce Medio 436-2048



**MOD. Q-194 V01-DX**  
Struttura PVC Blu Cobalto





**OBELIX ATENA**  
RIVESTIMENTI PVC



**MOD. P-087**  
Struttura PVC Rovere Gold 436-2036



**MOD. P-085**  
Struttura PVC Rovere Gold 436-2036



# OBELIX ATENA

DISEGNI RIVESTIMENTI PVC

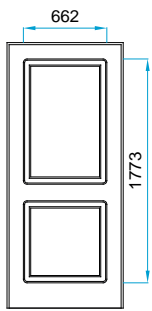

P-006

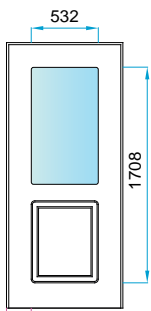

195 Q-006-V01

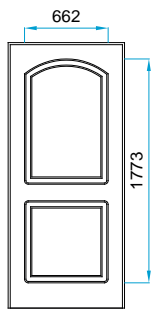

P-007

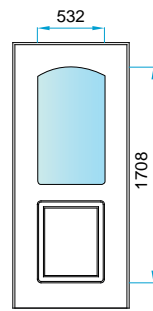

Q-007-V01

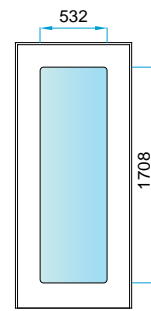

Q-010-V01

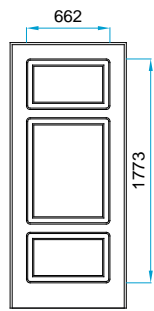

P-014

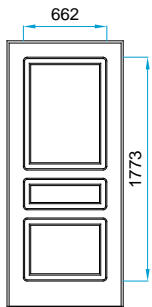

P-015

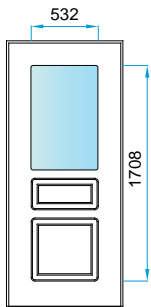

Q-015-V01

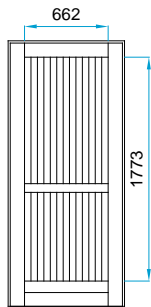

P-016

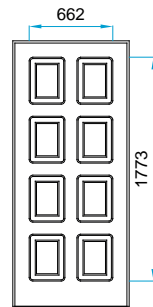

P-022

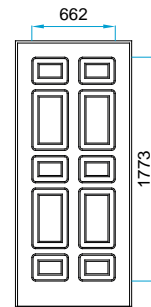

P-024

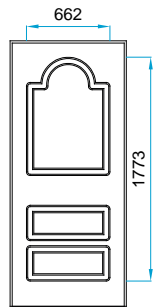

P-025

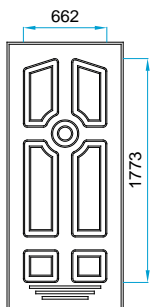

P-028

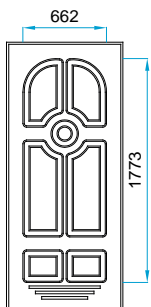

P-034

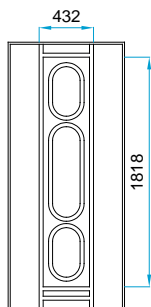

P-035

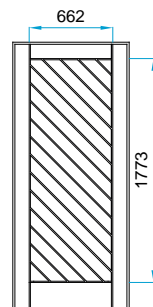

P-042

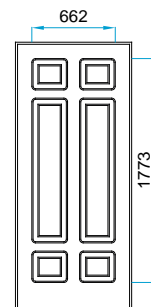

P-043

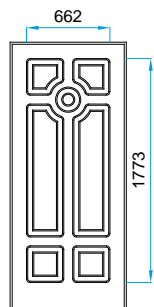

P-062

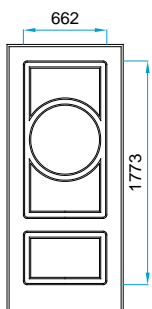

P-063

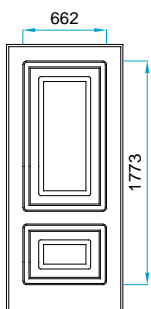

P-067

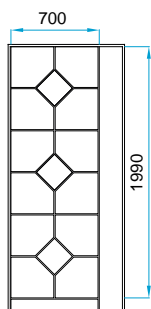

P-080-SX

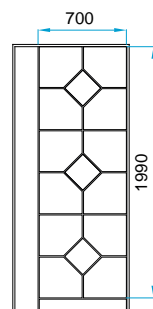

P-080-DX

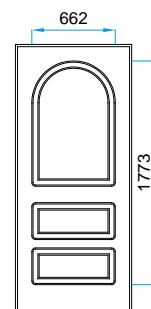

P-085

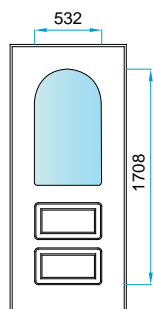

Q-085-V01

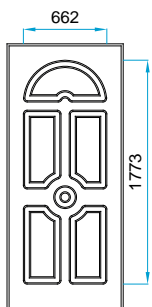

P-087

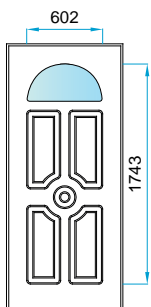

160 Q-087-V01

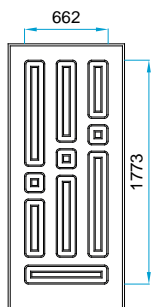

P-090

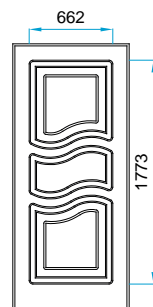

P-092-SX

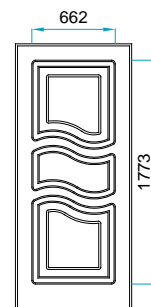

P-092-DX

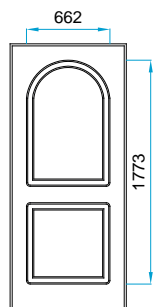

P-102



# OBELIX ATENA

DISEGNI RIVESTIMENTI PVC

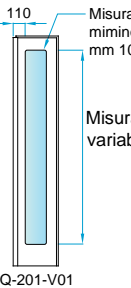
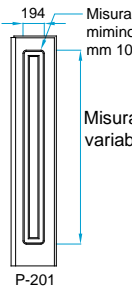
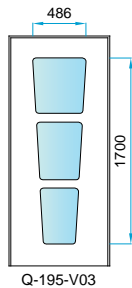
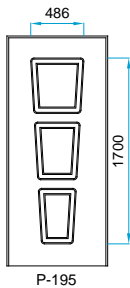
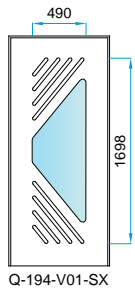
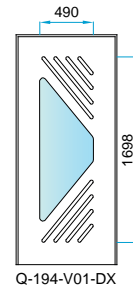
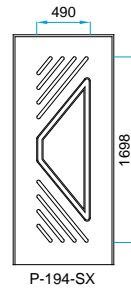
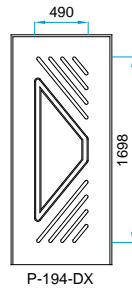
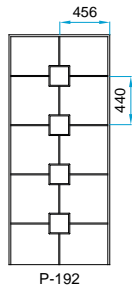
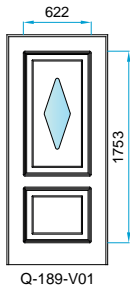
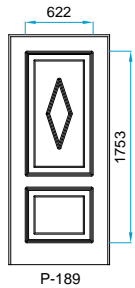
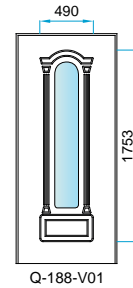
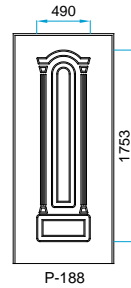
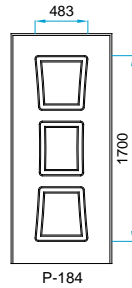
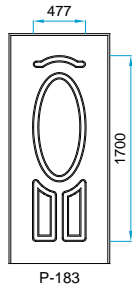
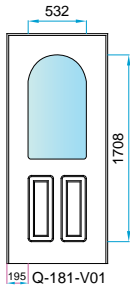
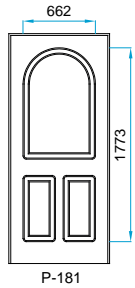
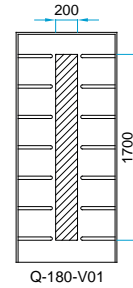
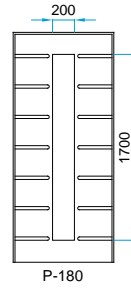
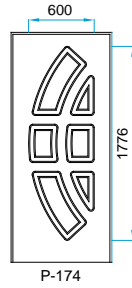
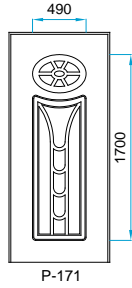
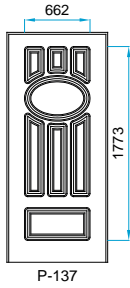
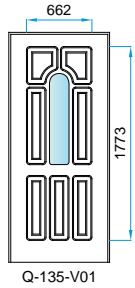
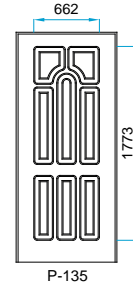
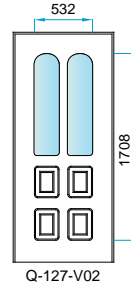
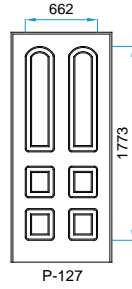
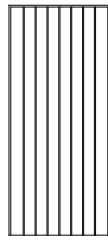
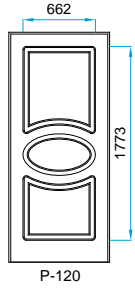
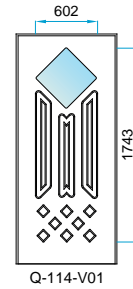
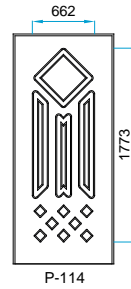
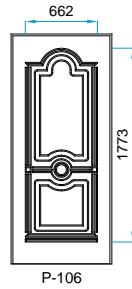
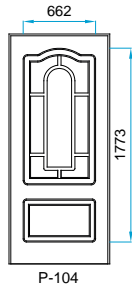
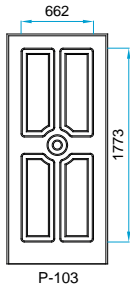
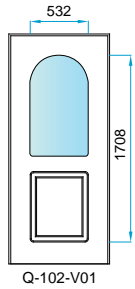

Misura variabile  
minimo lavorazione  
mm 100

Misura  
variabile

Misura variabile  
minimo vetro  
mm 100

Misura  
variabile





 **FERRARO**  
LIVING®

GRATE



# OBELIX GRATE

GRATE IN ACCIAIO ZINCATO



**MOD. Grata forata "D" a campione**  
Acciaio zincato  
Antracite gofrato



**MOD. Classico 25x200**  
Acciaio zincato  
Antracite gofrato



**MOD. Grata Liberty LA (lucernario)**  
**MOD. Grata Liberty a campione**  
Acciaio zincato  
Antracite gofrato

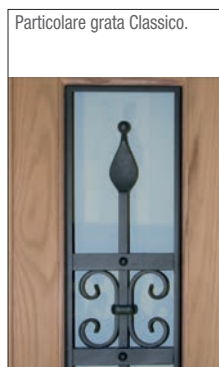



# OBELIX GRATE

DESIGN GRATE IN ACCIAIO ZINCATO

## GRATA FORATA

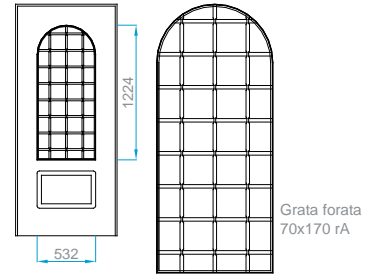
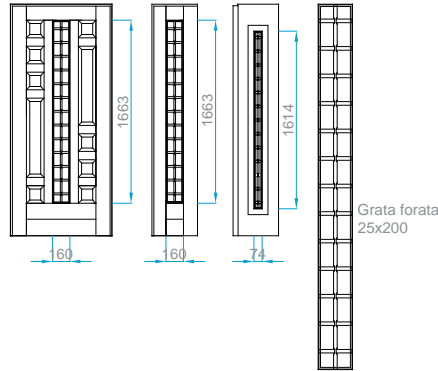
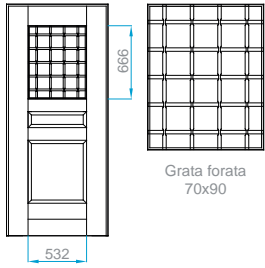

## GRATA FORATA "D"

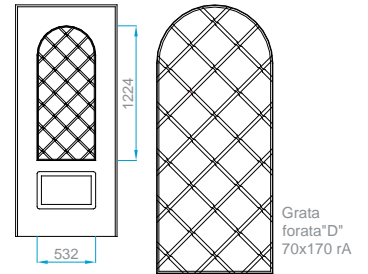
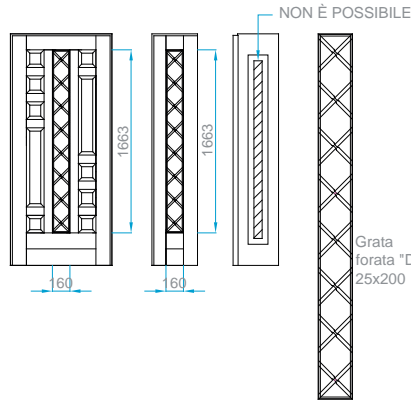
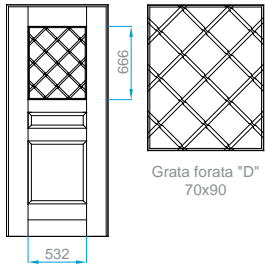

## CLASSICO

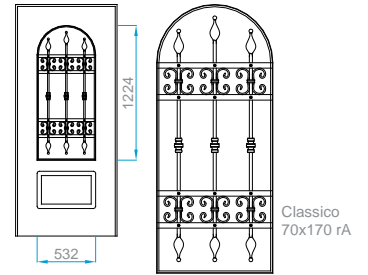
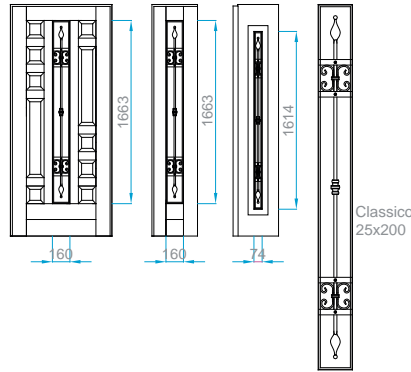
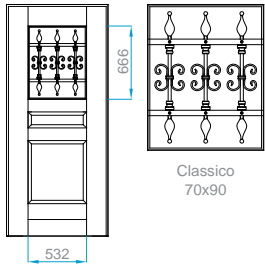

## LIBERTY

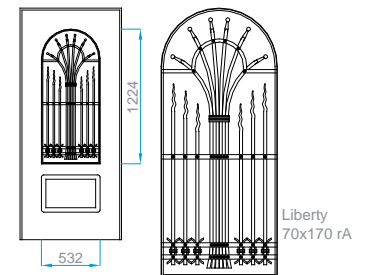
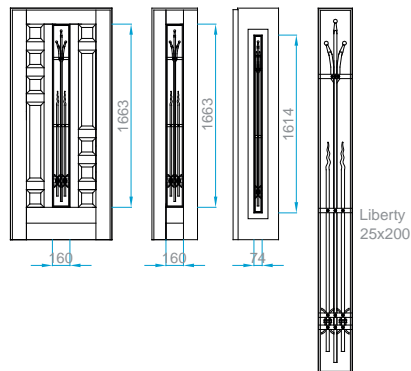
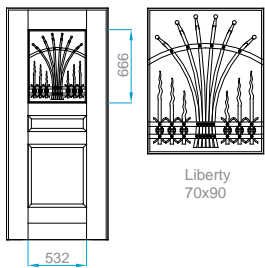





# OBELIX GRATE

DESIGN GRATE IN ACCIAIO ZINCATO

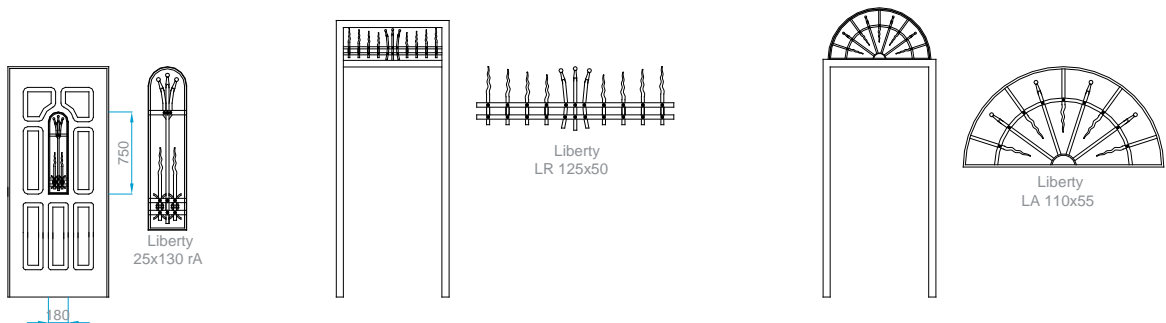
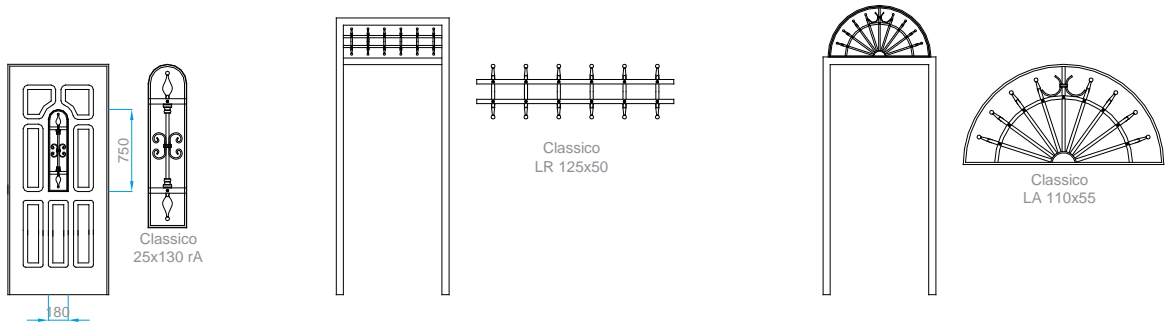
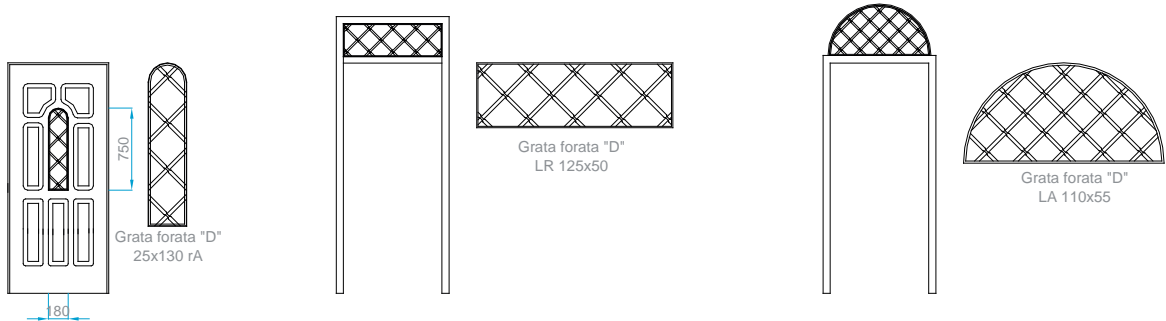
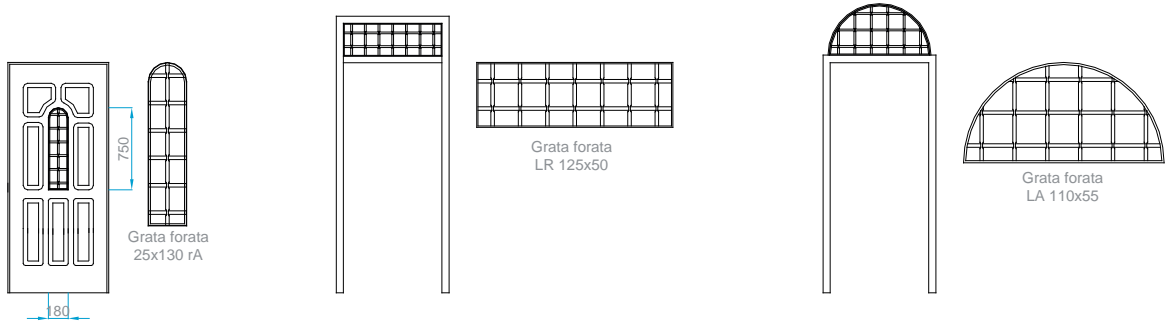



# OBELIX INFORMAZIONI TECNICHE

RIVESTIMENTI LISCI FUTURA 1 ANTA

76

## RIVESTIMENTI LISCI mm 7 PER PORTA UNA ANTA 90x210 DX

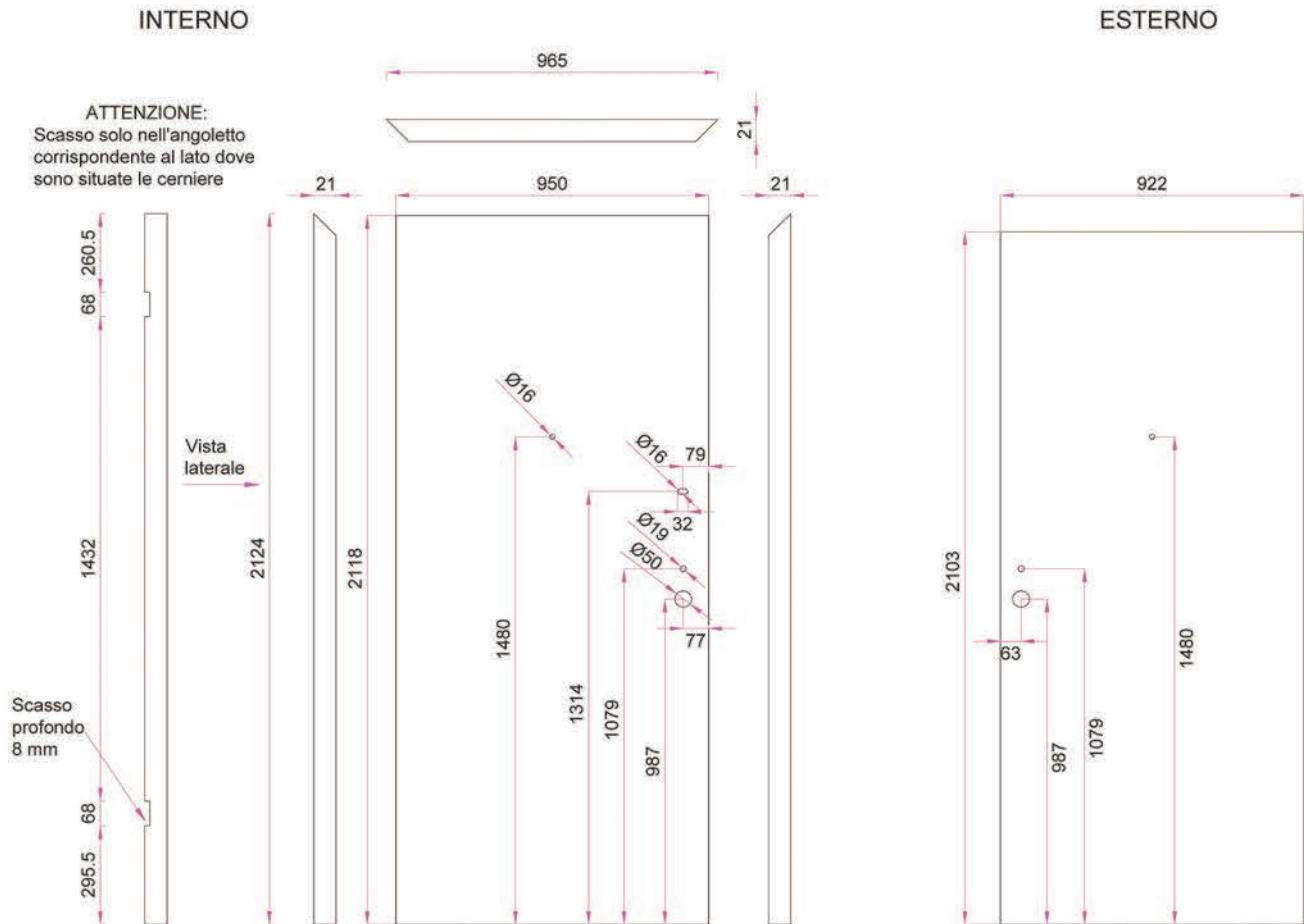

SEZIONE ANGOLETTO

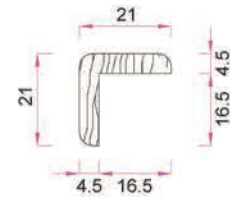

Pannello interno	larghezza	luce passaggio + 50	$900 + 50 = 950$
	altezza	luce passaggio + 18	$2100 + 18 = 2118$
Pannello esterno	larghezza	luce passaggio + 22	$900 + 22 = 922$
	altezza	luce passaggio + 3	$2100 + 3 = 2103$
Angoletto interno	larghezza	luce passaggio + 65	$900 + 65 = 965$
	altezza	luce passaggio + 24	$2100 + 24 = 2124$



# OBELIX INFORMAZIONI TECNICHE

RIVESTIMENTI LISCI FUTURA 2 ANTE

RIVESTIMENTI LISCI mm 7 per PORTA DUE ANTE 120x210.80 Dx

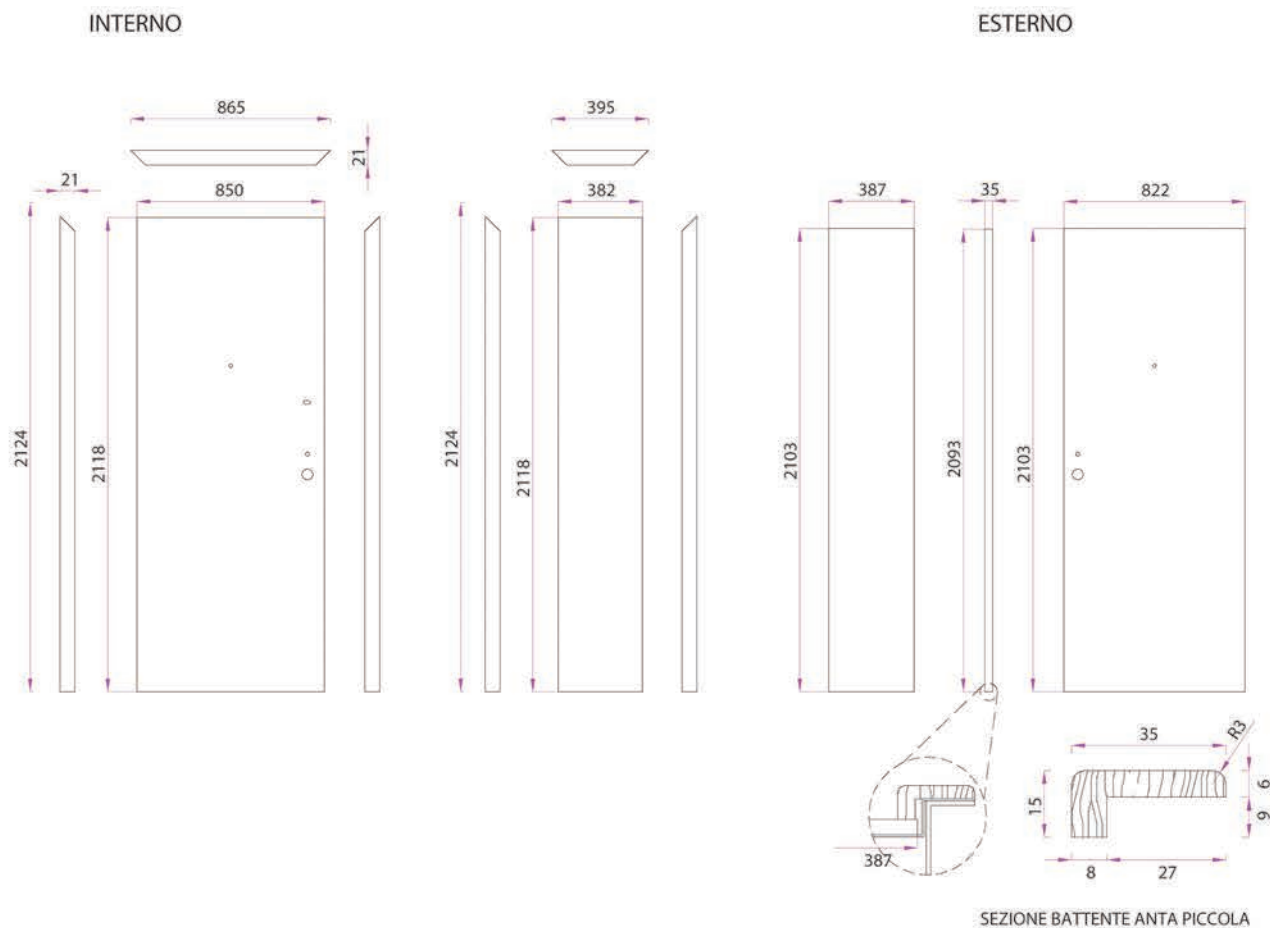

Pannello interno	anta apribile	larghezza	luce passaggio + 50	$800 + 50 = 850$
	anta apribile	altezza	luce passaggio + 18	$2100 + 18 = 2118$
	anta fissa	larghezza	luce passaggio - 800 - 18	$1200 - 800 - 18 = 382$
	anta fissa	altezza	luce passaggio + 18	$2100 + 18 = 2118$
Pannello esterno	anta apribile	larghezza	luce passaggio + 22	$800 + 22 = 822$
	anta apribile	altezza	luce passaggio + 3	$2100 + 3 = 2103$
	anta fissa	larghezza	luce passaggio - 800 - 13	$1200 - 800 - 13 = 387$
	anta fissa	altezza	luce passaggio + 3	$2100 + 3 = 2103$
Angoletto interno	anta apribile	larghezza	luce passaggio + 65	$800 + 65 = 865$
	anta apribile	altezza	luce passaggio + 24	$2100 + 24 = 2124$
	anta fissa	larghezza	luce passaggio - 800 - 5	$1200 - 800 - 5 = 395$
	anta fissa	altezza	luce passaggio + 24	$2100 + 24 = 2124$
Battente anta piccola		altezza	luce passaggio - 7	$2100 - 7 = 2093$





# OBELIX INFORMAZIONI TECNICHE

RIVESTIMENTI PANTOGRAFATI OMNIA · RIVESTIMENTI MASSELLO VICTORIA

78

RIVESTIMENTI PANTOGRAFATI mm15 · RIVESTIMENTI MASSELLO mm20 PER PORTA 1 ANTA 90X210 DX

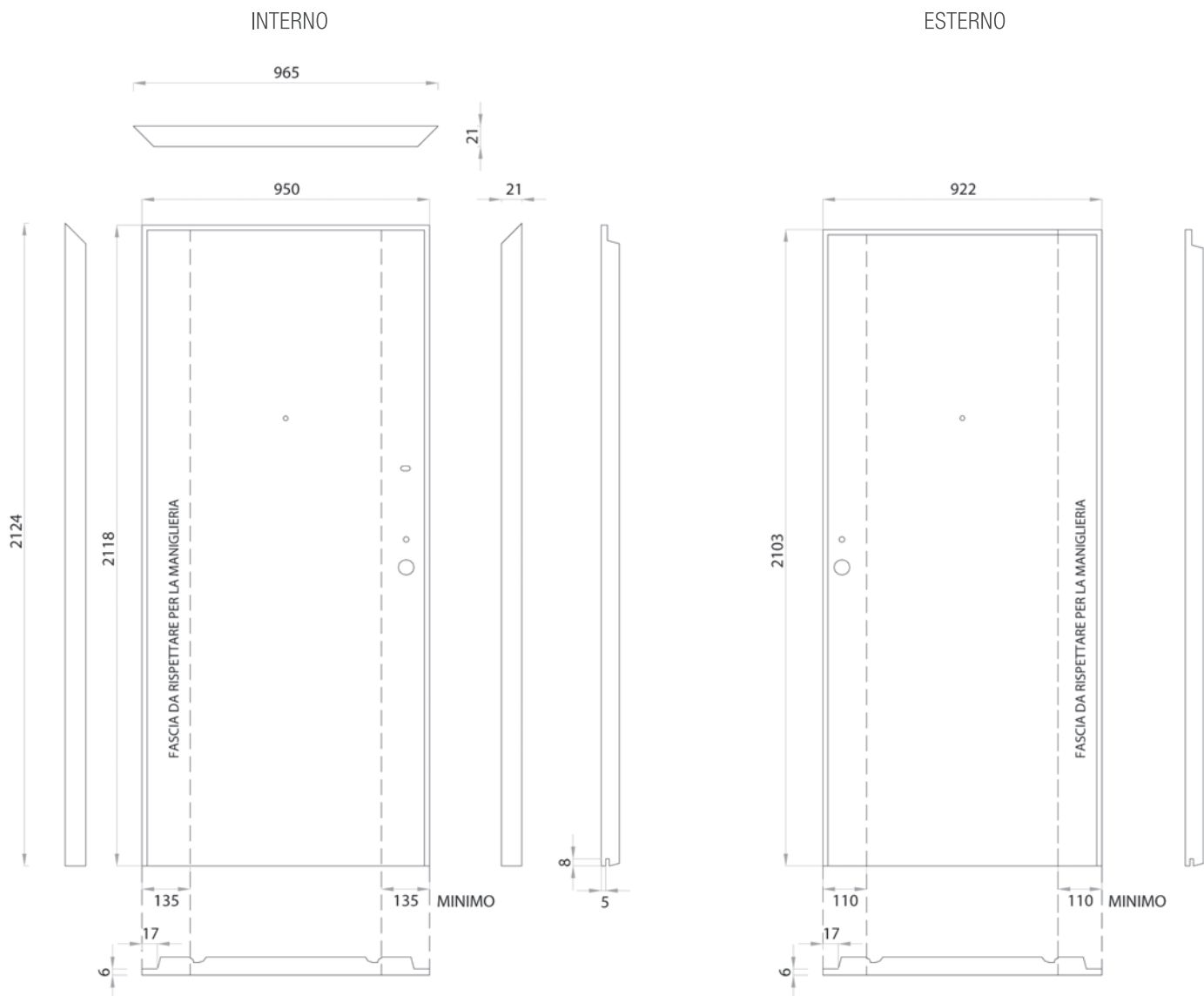

Pannello interno	larghezza	luce passaggio + 50	$900 + 50 = 950$
	altezza	luce passaggio + 18	$2100 + 18 = 2118$
Pannello esterno	larghezza	luce passaggio + 22	$900 + 22 = 922$
	altezza	luce passaggio + 3	$2100 + 3 = 2103$
Angoletto interno	larghezza	luce passaggio + 65	$900 + 65 = 965$
	altezza	luce passaggio + 24	$2100 + 24 = 2124$



RIVESTIMENTI PANTOGRAFATI mm19 · RIVESTIMENTI MASSELLO mm20 PER PORTA 2 ANTE 120x210.80  
INTERNO ESTERNO

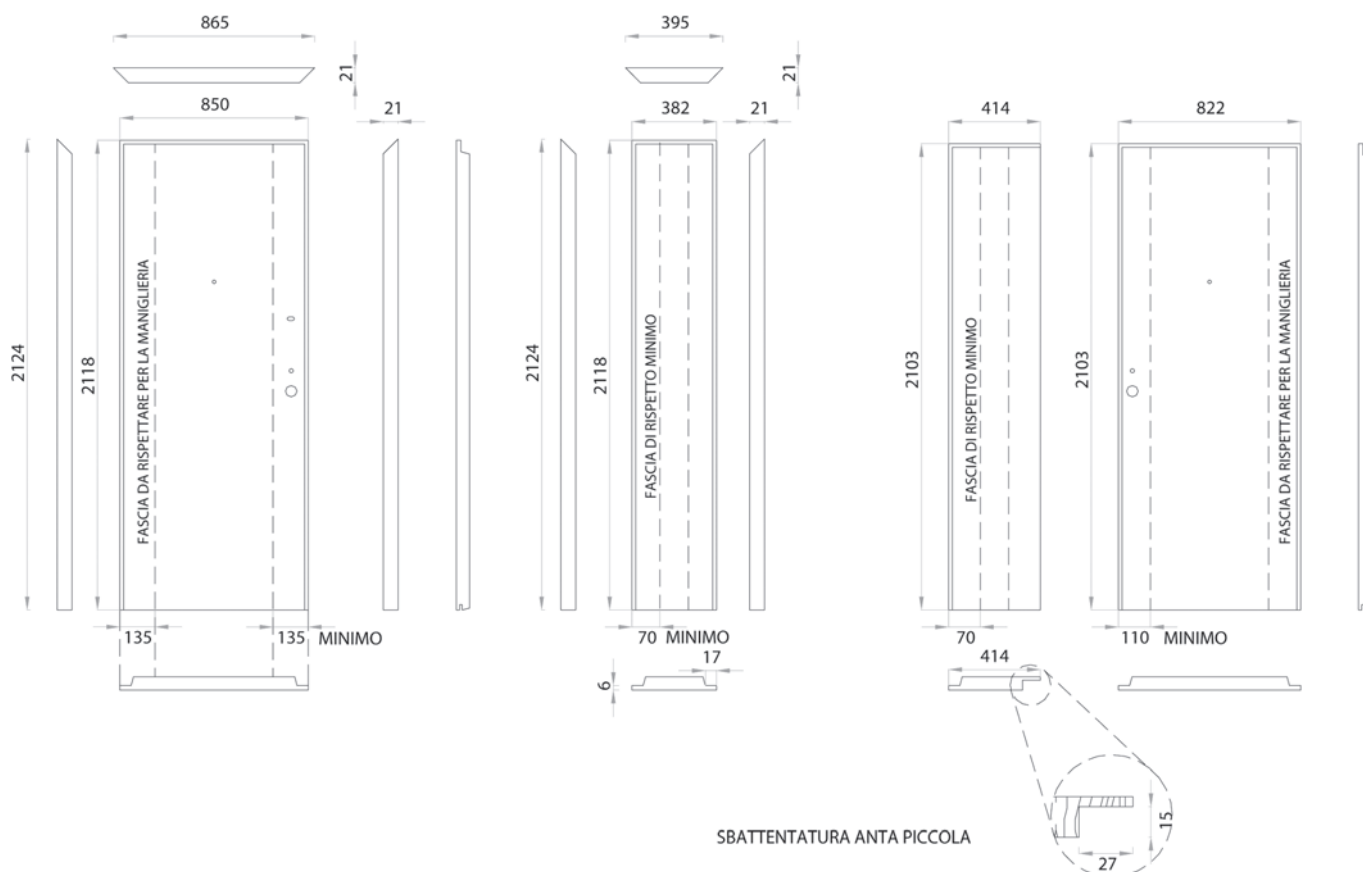

Pannello interno	anta apribile	larghezza	luce passaggio + 50	$800 + 50 = 850$
	anta apribile	altezza	luce passaggio + 18	$2100 + 18 = 2118$
	anta fissa	larghezza	luce passaggio - 800 - 18	$1200 - 800 - 18 = 382$
	anta fissa	altezza	luce passaggio + 18	$2100 + 18 = 2118$
Pannello esterno	anta apribile	larghezza	luce passaggio + 22	$800 + 22 = 822$
	anta apribile	altezza	luce passaggio + 3	$2100 + 3 = 2103$
	anta fissa	larghezza	luce passaggio - 800 + 14	$1200 - 800 + 14 = 414$
	anta fissa	altezza	luce passaggio + 3	$2100 + 3 = 2103$
Angoletto interno	anta apribile	larghezza	luce passaggio + 65	$800 + 65 = 865$
	anta apribile	altezza	luce passaggio + 24	$2100 + 24 = 2124$
	anta fissa	larghezza	luce passaggio - 800 - 5	$1200 - 800 - 5 = 395$
	anta fissa	altezza	luce passaggio + 24	$2100 + 24 = 2124$



# OBELIX INFORMAZIONI TECNICHE

RIVESTIMENTI ALLUMINIO ARCADIA 2 ANTE

RIVESTIMENTI IN ALLUMINIO spessore mm 7 per PORTA DUE ANTE 120x210.80 Dx

ESTERNO

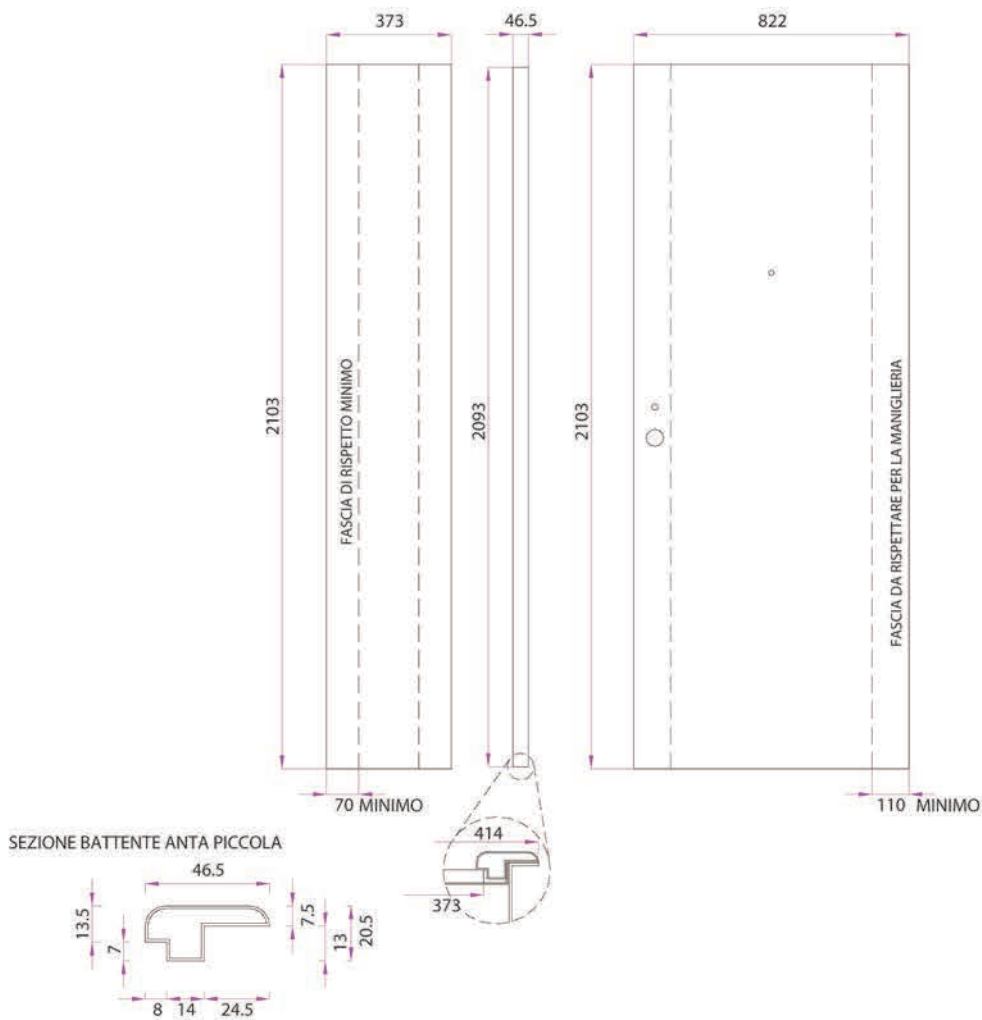

Pannello esterno	anta apribile	larghezza	luce passaggio + 22	$800 + 22 = 822$
	anta apribile	altezza	luce passaggio + 3	$2100 + 3 = 2103$
	anta fissa	larghezza	luce passaggio - 800 - 27	$1200 - 800 - 27 = 373$
	anta fissa	altezza	luce passaggio + 3	$2100 + 3 = 2103$
Battente anta piccola		altezza	luce passaggio - 7	$2100 - 7 = 2093$





# OBELIX INFORMAZIONI TECNICHE

RIVESTIMENTI PVC ATENA 2 ANTE

RIVESTIMENTI PVC SPESSORE mm 12 per PORTA DUE ANTE 120x210.80 Dx

INTERNO

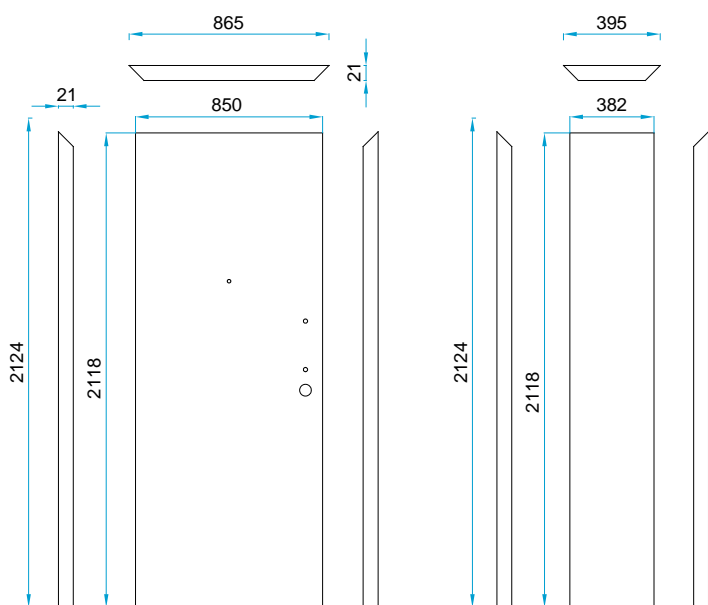

ESTERNO

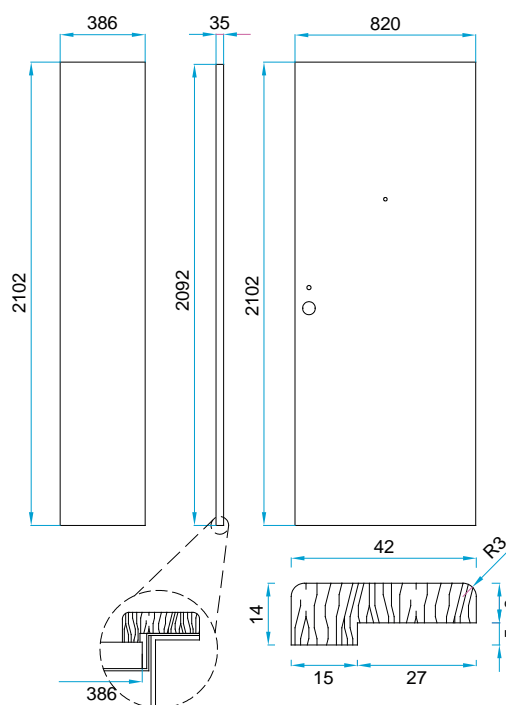

SEZIONE BATTENTE ANTA PICCOLA

Pannello interno	anta apribile	larghezza	luce passaggio + 50	$800 + 50 = 850$
	anta apribile	altezza	luce passaggio + 18	$2100 + 18 = 2118$
	anta fissa	larghezza	luce passaggio - 800 - 18	$1200 - 800 - 18 = 382$
	anta fissa	altezza	luce passaggio + 18	$2100 + 18 = 2118$
Pannello esterno	anta apribile	larghezza	luce passaggio + 20	$800 + 20 = 820$
	anta apribile	altezza	luce passaggio + 2	$2100 + 2 = 2102$
	anta fissa	larghezza	luce passaggio - 800 - 14	$1200 - 800 - 14 = 386$
	anta fissa	altezza	luce passaggio + 2	$2100 + 2 = 2102$
Angoletto interno	anta apribile	larghezza	luce passaggio + 65	$800 + 65 = 865$
	anta apribile	altezza	luce passaggio + 24	$2100 + 24 = 2124$
	anta fissa	larghezza	luce passaggio - 800 - 5	$1200 - 800 - 5 = 395$
	anta fissa	altezza	luce passaggio + 24	$2100 + 24 = 2124$
Battente anta piccola		altezza	luce passaggio - 8	$2100 - 8 = 2092$



# OBELIX INFORMAZIONI TECNICHE

LEGENDA SIMBOLOGIA FERRARO

82



POSA INTERNA:

*Per i rivestimenti con questo simbolo l'applicazione ideale è in ambienti interni. Evitare l'esposizione al sole e agli agenti atmosferici*



POSA ESTERNA  
MOLTO RIPARATA:

*per i rivestimenti con questo simbolo è consentita l'applicazione in ambienti esterni non esposti al sole, pioggia, e salinità*



POSA ESTERNA  
RIPARATA:

*i rivestimenti con questo simbolo possono essere applicati in ambienti esterni con una limitata esposizione al sole, pioggia, e salinità*



POSA ESTERNA:

*per i rivestimenti con questo simbolo è consentita l'applicazione in ambienti esterni, ma con una limitata azione salina*

GARANZIA:

*per i rivestimenti Futura, Edison, Omnia, e Victoria, rispettando le applicazioni di cui sopra, la garanzia è di anni 5, mentre per quelli Arcadia è di anni 10.*

L'azienda Ferraro Group srl, si riserva il diritto di modificare le caratteristiche senza preavviso.  
Le informazioni e i colori contenuti sono da considerarsi puramente indicativi, non vincolanti e non costituiscono offerta di prodotti.  
Per ulteriori informazioni si prega di contattare i nostri uffici tecnici.





**FERRARO®**

FERRARO GROUP SRL  
S.S.90 Delle Puglie Km 33,  
Contrada Camporeale Zona P.I.P.  
ITA 83031 ARIANO IRPINO AV  
Phone: +39 0825 881321  
Fax: +39 0825 881638  
Mail: [info@ferraroporte.com](mailto:info@ferraroporte.com)  
Posizione GPS sede:  
N 41.19829 E 15.13919  
[ferraroporte.com](http://ferraroporte.com)  
[sezionali.it](http://sezionali.it)

